

REVISIONS			
REV.	DESCRIPTION	DATE	ENG
A	INITIAL REV.	08/22/22	MOB

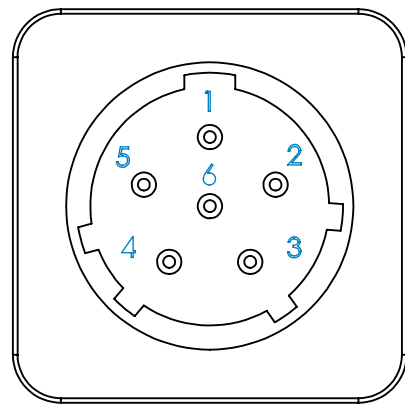
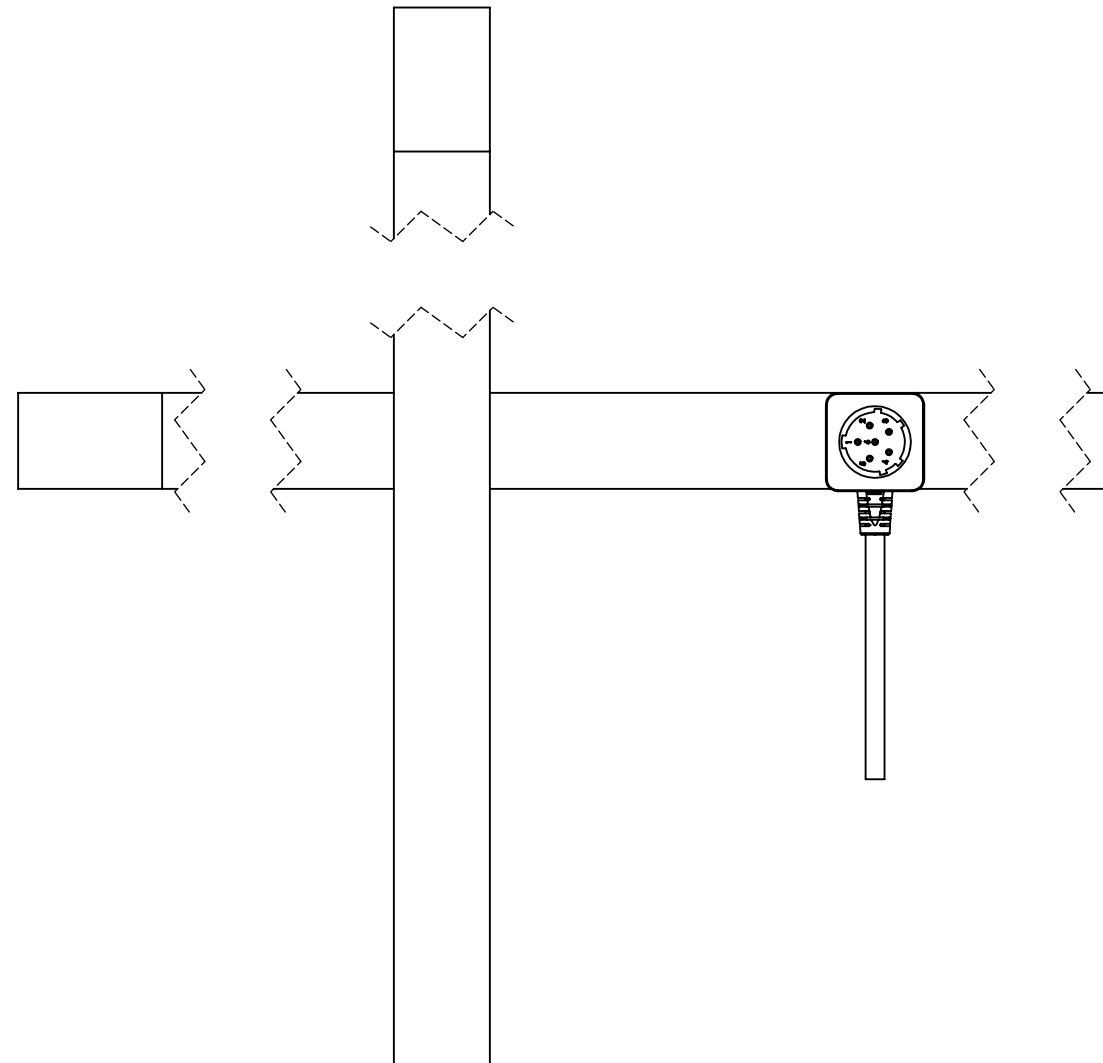
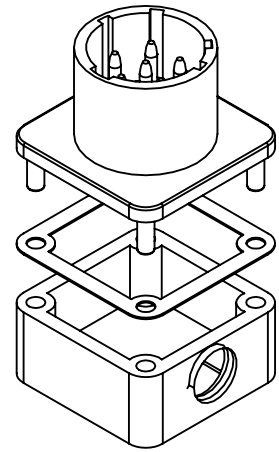

CONN-BA5590 PINOUT  
(FRONT VIEW)

BILL OF MATERIALS			
ITEM NO.	PART NO.	QTY	NAME/DESCRIPTION
1	CONN-BA5590-MTV	1	BA5590 CONNECTOR WITH 8MM THREADED BACKSHELL AND VELCRO STRAP
2	BA-5590-GASKET	1	GASKET
3	SN-359-T3	1	CABLE, AWG 20, 2C, WITH 8MM STRAIN RELIEF

UNLESS OTHERWISE SPECIFIED:  
 DIMENSIONS ARE IN: INCHES  
 TOLERANCES: .XX: ± 0.03  
 .XXX: ± 0.005  
 ANGULAR: .X°: 1°  
 .XX°: 0.5°  
 BREAK EDGES: .005 - .020  
 FILLETS: .005 - .020  
 SURFACE FINISH:  
 GEOMETRIC TOLERANCING  
 PER: ASME Y14.5 -2009  
 MATERIAL: SEE DRAWING NOTES  
 FINISH: SEE DRAWING NOTES  
 DO NOT SCALE DRAWING

	NAME	DATE
DRAWN	MOB	08/22/22
CHECKED	RB	08/22/22
COMMENTS:		
<b>PROPRIETARY AND CONFIDENTIAL</b> THE INFORMATION CONTAINED IN THIS DRAWING IS THE SOLE PROPERTY OF SUPPLYNET, INC. ANY REPRODUCTION IN PART OR AS A WHOLE WITHOUT THE WRITTEN PERMISSION OF SUPPLYNET INC. IS PROHIBITED.		
<b>CAGE CODE: 1HJX9</b>		

REF. NUMBER: SNO634

**SupplyNet** 706 EXECUTIVE BLVD  
SUITE B  
VALLEY COTTAGE, NY 10989

TITLE:  
**BA5590 MALE CONNECTOR WITH THREADED BACKSHELL AND VELCRO STRAP, KIT**

SIZE	DWG. NO.	REV
<b>B</b>	<b>CONN-BA5590-MTV-KIT</b>	<b>A</b>

SCALE: NA WEIGHT: SHEET 1 OF 2

# ASSEMBLY INSTRUCTIONS

\*VELCRO STRAP NOT SHOWN

**1. PLACE SMALL AMOUNT OF CYANOACRYLATE GLUE  
THREADS OF STRAIN RELIEF AND SCREW INTO THREADED BACKSHELL.**

**2. PEEL OFF BACKING ON 1 SIDE OF GASKET.  
PLACE GASKET ONTO PERIMETER OF CONNECTOR.  
USING CORNER POSTS AS GUIDES.**

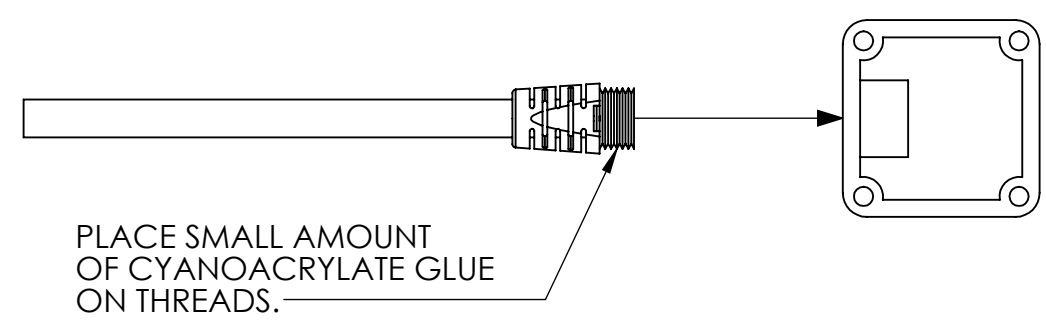

PLACE SMALL AMOUNT  
OF CYANOACRYLATE GLUE  
ON THREADS.

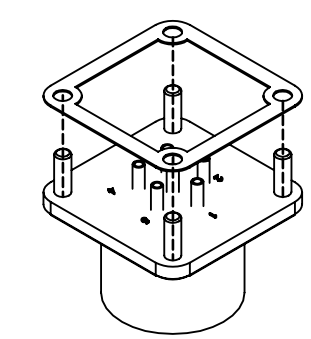
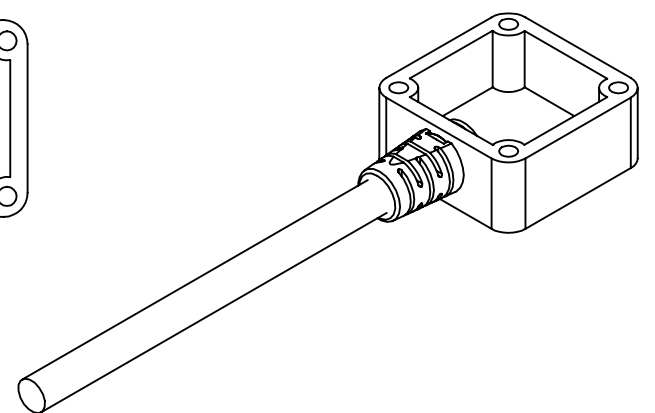

**3. SOLDER WIRES TO PINS ON  
CONNECTOR.**

**4. REMOVE REMAINING BACKING FROM GASKET, PLACE SMALL DROP OF GLUE ONTO  
CONNECTOR POSTS, INSERT POSTS INTO BACKSHELL, AND APPLY LIGHT PRESSURE  
TO SQUEEZE BACKSHELL AND CONNECTOR TOGETHER. HOLD PRESSURE FOR 3-5 SECONDS  
TO GIVE GLUE AND GASKET TIME TO ADHERE.**

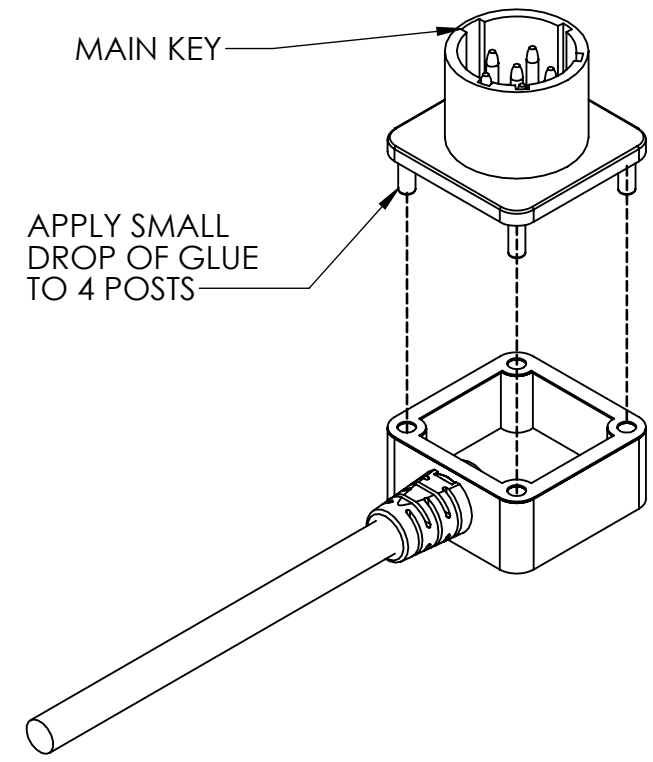
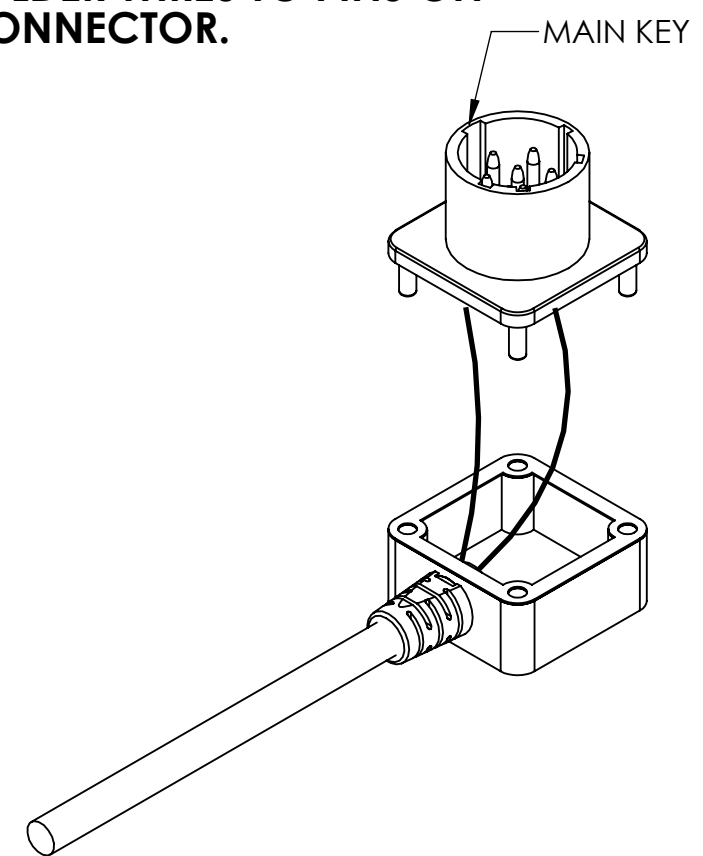

APPLY SMALL  
DROP OF GLUE  
TO 4 POSTS

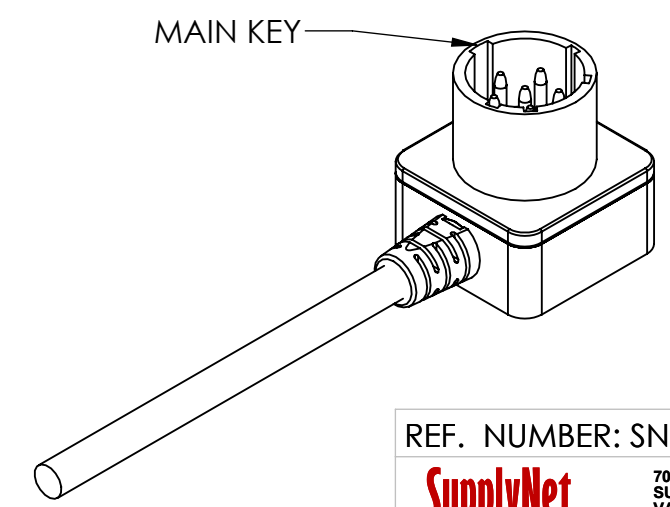

REF. NUMBER: SN0634

**SupplyNet**

706 EXECUTIVE BLVD  
SUITE B  
VALLEY COTTAGE, NY 10989

TITLE:  
**BA5590 MALE CONNECTOR  
WITH THREADED BACKSHELL  
AND VELCRO STRAP, KIT**

SIZE <b>B</b>	DWG. NO. <b>CONN-BA5590-MTV-KIT</b>	REV <b>A</b>
------------------	--	-----------------

**PROPRIETARY AND CONFIDENTIAL**  
THE INFORMATION CONTAINED IN THIS  
DRAWING IS THE SOLE PROPERTY OF  
SUPPLYNET, INC. ANY REPRODUCTION  
IN PART OR AS A WHOLE WITHOUT THE  
WRITTEN PERMISSION OF SUPPLYNET INC.  
IS PROHIBITED.

DO NOT SCALE DRAWING

**CAGE CODE: 1HJX9**

SCALE: NA

WEIGHT:

SHEET 2 OF 2