

TABLE 1: WIRE RUN LIST	
P1 (ITEM 1)	COLOR
1	RED
2	BLACK
3	BROWN
4	GREEN
5	WHITE
6	ORANGE
SHELL	SHIELD

TWISTED PAIR

SEE NOTE #7

TABLE 2: WIRE LENGTH CHART		
PART NUMBER & PART MARKING	"-XX" DIMENSION (INCHES)	TOLERANCE (INCHES)
SN-1087-8mm-0.5	6	+1.0", -0.0"
SN-1087-8mm-01	12	+1.0", -0.0"
SN-1087-8mm-02	24	+2.0", -0.0"
SN-1087-8mm-03	36	+2.0", -0.0"
SN-1087-8mm-04	48	+2.0", -0.0"
SN-1087-8mm-06	72	+4.0", -0.0"
SN-1087-8mm-08	96	+4.0", -0.0"
SN-1087-8mm-10	120	+6.0", -0.0"
SN-1087-8mm-12	144	+6.0", -0.0"
SN-1087-8mm-18	216	+6.0", -0.0"
SN-1087-8mm-20	240	+6.0", -0.0"
SN-1087-8mm-25	300	+6.0", -0.0"
SN-1087-8mm-30	360	+18.0", -0.0"

REV	DATE	DESCRIPTION OF CHANGE	ENG
1	8/25/2021	UNDER CUSTOMER REVIEW	TC

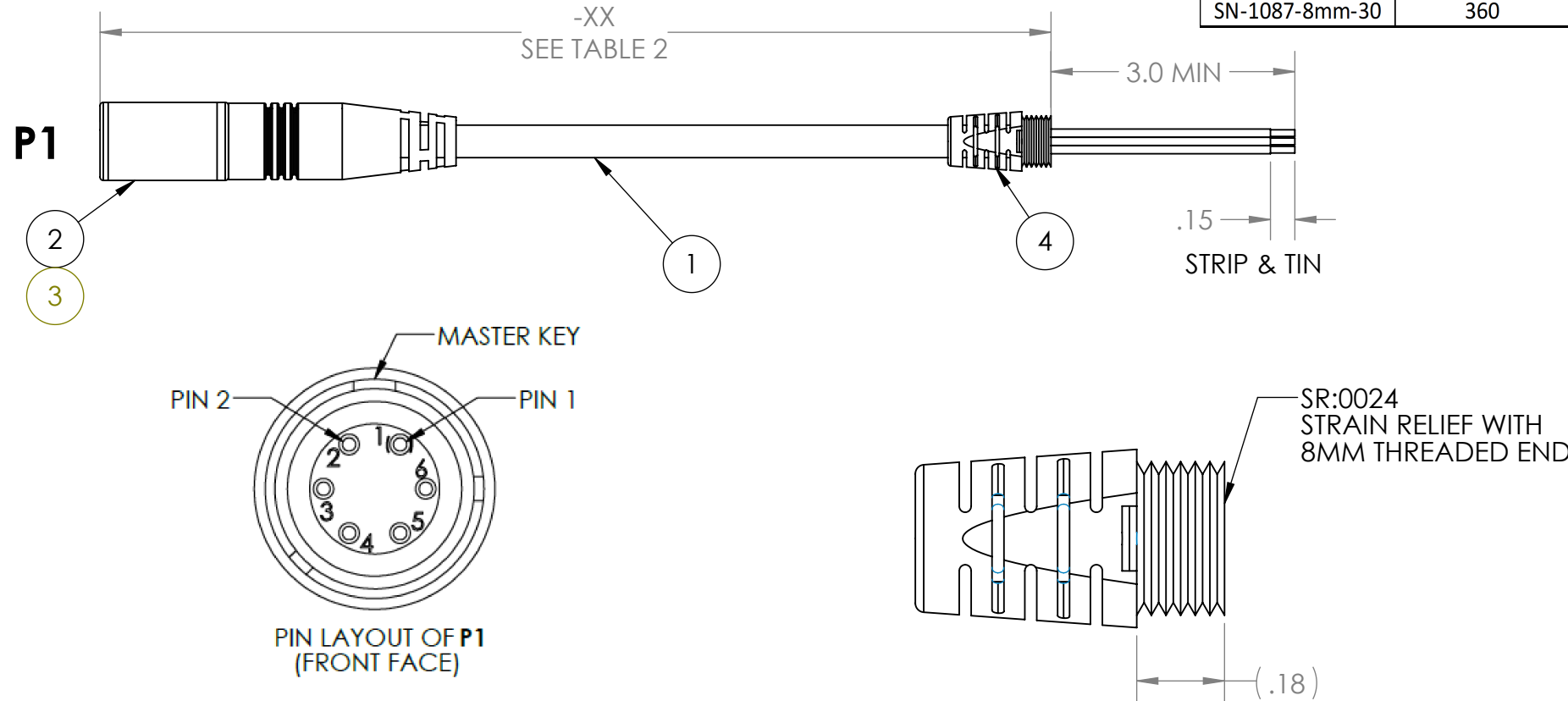

BILL OF MATERIALS			
ITEM NO.	PART NUMBER	QTY	NAME
1	BN226422FEPSSIL	1	6C, SHEILDDED, SILICONE JACKET, OD: 0.20"
2	807-348-01ZNU6-6SY	1	CONNECTOR, FEMALE, GLENAIR, 6 PIN
3	BE-04	1	STEEL BANDING
4	SR:0024	1	8mm THREADED STRAIN RELIEF, PU, BLK

NOTES:

- SOLDERING IAW IPC-J-STD-001 CLASS II AS APPLICABLE.
- CABLE ASSEMBLIES TO BE TESTED 100% FOR CONTINUITY AND SHORTS.
- ALL SOLDERED PINS ARE TO BE TESTED 100% FOR INSULATION RESISTANCE. (150 VDC @100 MOHM MINIMUM) EXCLUDE CHASSIS GROUND FROM THIS TEST.
- IDENTIFICATION: COMPLETED ASSEMBLIES ARE TO BE PLACED IN A ZIP POLY-BAG. PLACE A LABEL ON THE BAG WITH THE FOLLOWING INFORMATION. UOS PART MARKING ON THE WIRE IS PROHIBITED:  
**SN-1088-8mm-XX REV. X** (-XX AND REV X PER PO)  
**CAGE CODE: 1HJX9**  
**MFD: MM/YY** (MM = MONTH MANUFACTURED, YY = LAST TWO DIGITS OF YEAR MANUFACTURED)
- MANUFACTURE AND INSPECT IAW IPC/WHMA A-620 CLASS 2.
- WIRE PER TABLE 1.
- CONNECT TWISTED PAIR SHIELD/DRAIN WIRE TO OVERALL SHIELD AT BOTH ENDS OF CABLE.

UNLESS OTHERWISE SPECIFIED:	NAME	DATE
DIMENSIONS ARE IN: INCHES	DRAWN	TC 5/25/21
TOLERANCES: .XX: ± 0.03 .XXX: ± 0.005	CHECKED	RM 5/25/21
ANGULAR: .X°: 1° .XX°: 0.5°	COMMENTS:	
BREAK EDGES: .005 - .020	<b>PROPRIETARY AND CONFIDENTIAL</b> THE INFORMATION CONTAINED IN THIS DRAWING IS THE SOLE PROPERTY OF SUPPLYNET, INC. ANY REPRODUCTION IN PART OR AS A WHOLE WITHOUT THE WRITTEN PERMISSION OF SUPPLYNET INC. IS PROHIBITED.	
FILLETS: .005 - .020	<b>CAGE CODE: 1HJX9</b>	
SURFACE FINISH:	DO NOT SCALE DRAWING	
GEOMETRIC TOLERANCING PER: ASME Y14.5 -2009		
MATERIAL: SEE DRAWING NOTES		
FINISH: SEE DRAWING NOTES		

REF. NUMBER: SN0826

**SupplyNet** 706 EXECUTIVE BLVD.  
SUITE B  
VALLEY COTTAGE, NY 10989

TITLE:  
**NETT WARRIOR CABLE FEMALE TO 8mm STRAIN RELIEF**

SIZE <b>B</b>	DWG. NO. <b>SN-1088-8MM-XX</b>	REV <b>1</b>
------------------	-----------------------------------	-----------------

SCALE: NA WEIGHT: SHEET 1 OF 1