

TABLE 1. WIRE RUN LIST	
PIN NUMBER	WIRE COLOR
1	PURPLE
3	DARK BLUE **
7	LIGHT GREEN *
8	WHITE
9	PINK
10	GRAY
15	BROWN
16	RED
17	LIGHT BLUE *
18	YELLOW
19	DARK ORANGE **
20	BLUE
24	GREEN
25	TAN
28	BLACK
29	ORANGE
30	CLEAR
31	DARK GREEN **
32	CLEAR
E33, E34	BRAIDED SHIELD
* OPTIONAL WHITE BAND FOR CLARITY	
** OPTIONAL BLACK BAND FOR CLARITY	

TWISTED PAIR
TWISTED PAIR

PART NUMBER DESCRIPTION TE-32MZ-E-XX

= "L" CABLE LENGTH IN FEET. REF. TABLE 2.

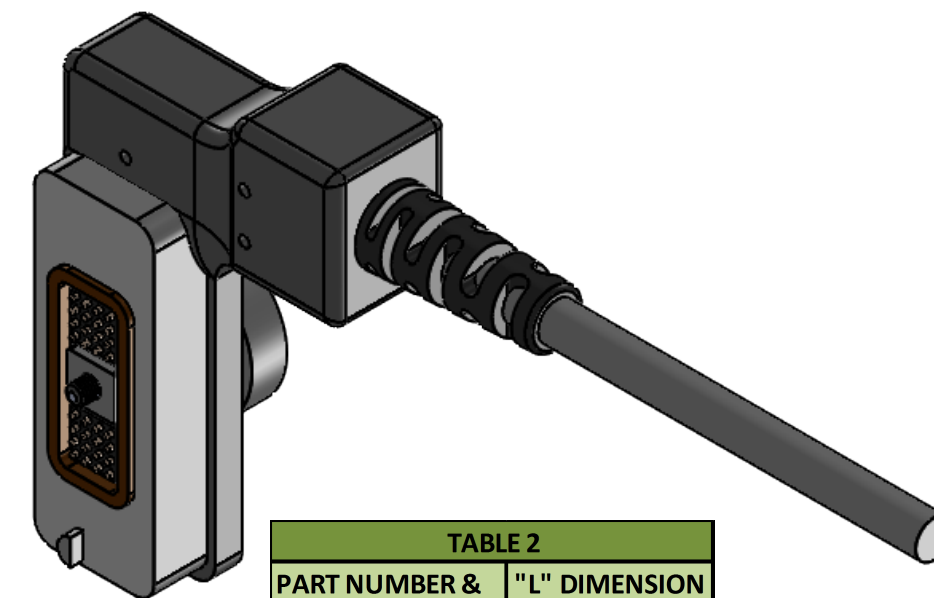
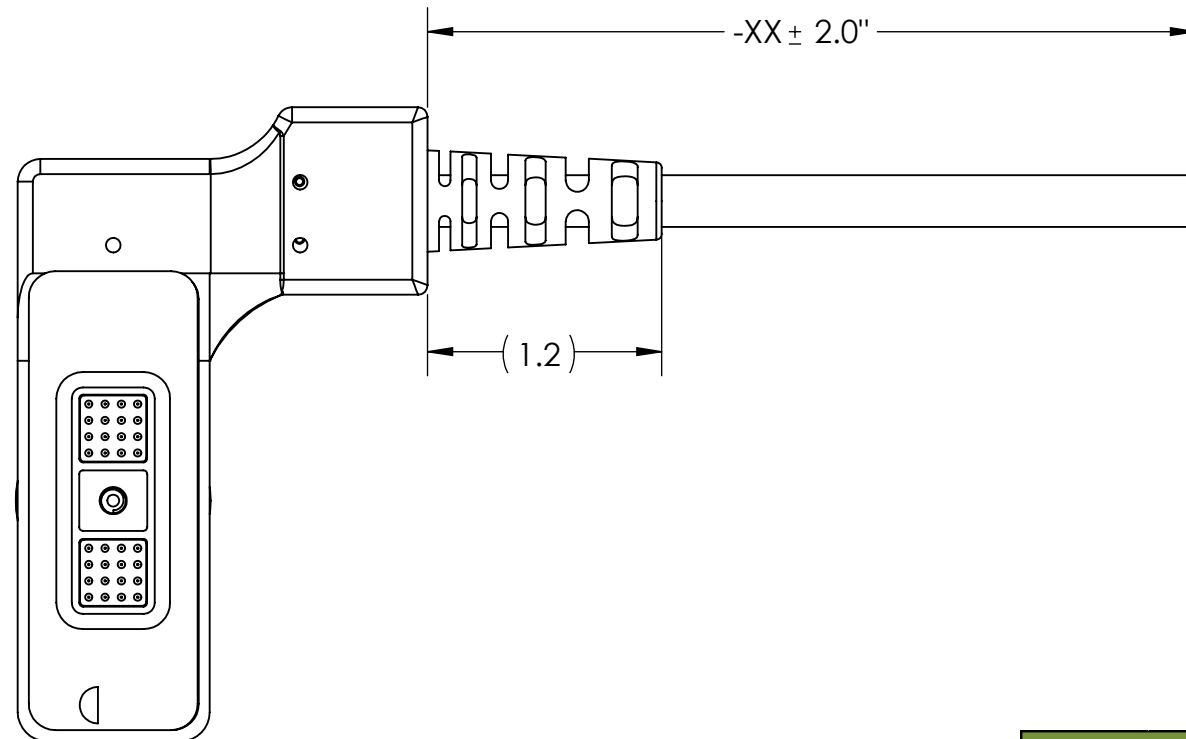

TABLE 2	
PART NUMBER & PART MARKING	"L" DIMENSION (FEET)
TE-32ML-E--03	3
TE-32ML-E--06	6
TE-32ML-E--08	8
TE-32ML-E--10	10
TE-32ML-E--12	12
TE-32ML-E--18	18
TE-32ML-E--20	20
TE-32ML-E--25	25
TE-32ML-E--30	30

BILL OF MATERIALS				
ITEM NO.	PART NUMBER	QTY	NAME	COMMENTS
1	51234	AR	WIRE	19 C CABLE
2	TE-32M-ASSY	1	CONNECTOR ASSEMBLY	INCLUDES HOUSING, FASTENERS, THUMBWHEEL. PROVIDED BY SUPPLYNET
3	24-7068-7601	AR	SOLDER, LEAD FREE	KESTER
4	SN0077	1	PCB	SUPPLYNET PROVIDED.

NOTES:

- CABLE: 26 AWG, 19 CONDUCTOR, OD: 0.270 NOMINAL. POLYURETHANE INSULATION. OUTER SHIELD 38 AWG, TIN PLATED COPPER BRAID, 90% COVERAGE.
- OVERMOLD MATERIAL: 90A POLYETHER-TYPE THERMOPLASTIC POLYURETHANE (TPU).
- JACKET: BLACK MATTE FINISH.
- E33,E34 IS CHASSIS GROUND
- SOLDERING IAW IPC-J-STD-001 CLASS II AS APPLICABLE.
- CABLE ASSEMBLIES TO BE 100% TESTED FOR CONTINUITY, SHORTS AND INSULATION RESISTANCE (250V @100MOHM MINIMUM)
- IDENTIFICATION: BAG AND IDENTIFY ON PACKAGING THE FOLLOWING INFORMATION FOR EACH PART DELIVERED. UOS PART MARKING ON THE WIRE IS PROHIBITED:
PN: TE-32MZ-E-XX REV X (REV MARKING PER PO & PN PER DESCRIPTION)
CAGE CODE: 1HJX9
DATE OF MFG: MM/YY
- WIRING FUNCTION: SEE TABLE 1 AND DRAWING SN0057.
- REFERENCE SUPPLYNET FILE NUMBER SN0069.
- MANUFACTURE AND INSPECT IAW IPC/WHMA A-620 CLASS 2.

UNLESS OTHERWISE SPECIFIED:	NAME	DATE
DIMENSIONS ARE IN: INCHES	DRAWN	TC 06/17/16
TOLERANCES: .XX: ± 0.03	CHECKED	RJB 06/17/16
.XXX: ± 0.005	COMMENTS:	
ANGULAR: .X°: 1°	PROPRIETARY AND CONFIDENTIAL	
.XX*: 0.5°	THE INFORMATION CONTAINED IN THIS DRAWING IS THE SOLE PROPERTY OF SUPPLYNET, INC. ANY REPRODUCTION IN PART OR AS A WHOLE WITHOUT THE WRITTEN PERMISSION OF SUPPLYNET INC. IS PROHIBITED.	
BREAK EDGES: .005 - .020	SIZE	DWG. NO.
FILLET: .005 - .020	B	TE-32MZ-E-XX
SURFACE FINISH:	REV	A
GEOMETRIC TOLERANCING PER: ASME Y14.5 -2009	SCALE: NA	WEIGHT:
MATERIAL: SEE DRAWING NOTES	CAGE CODE: 1HJX9	
FINISH: SEE DRAWING NOTES	SHEET 1 OF 1	
DO NOT SCALE DRAWING		

REF. NUMBER: SN0425
SupplyNet 706 EXECUTIVE BLVD. SUITE B VALLEY COTTAGE, NY 10989
TITLE: REAR EXIT PRC-117G 32 PIN DATA CABLE, J3 PORT.
SCALE: NA WEIGHT: SHEET 1 OF 1