

REV	DATE	DESCRIPTION OF CHANGE	ENG
A	7/26/16	INITAL REV.	TC

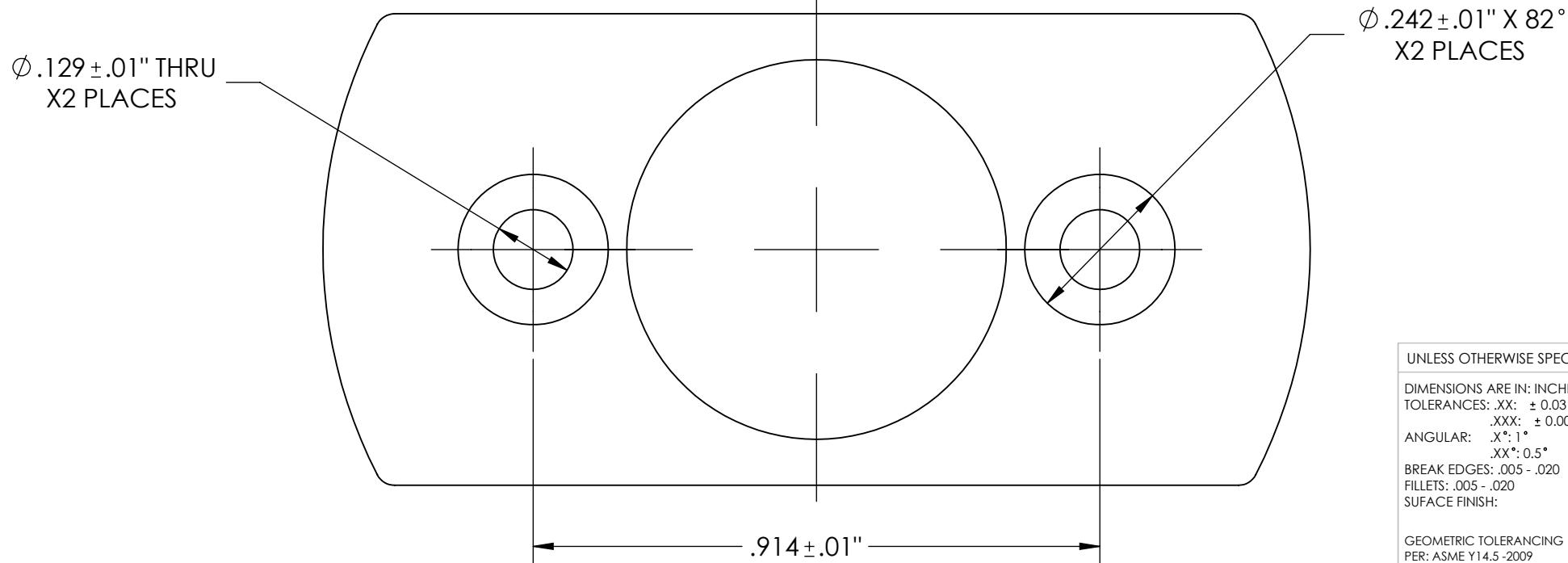
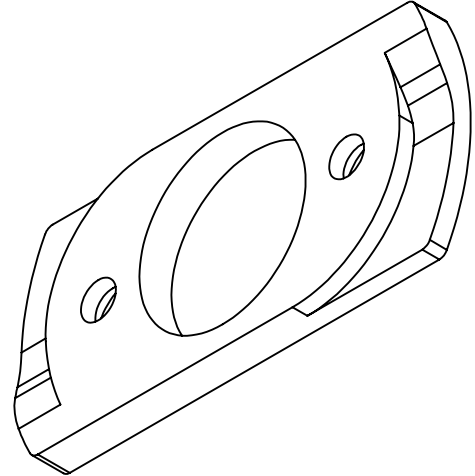
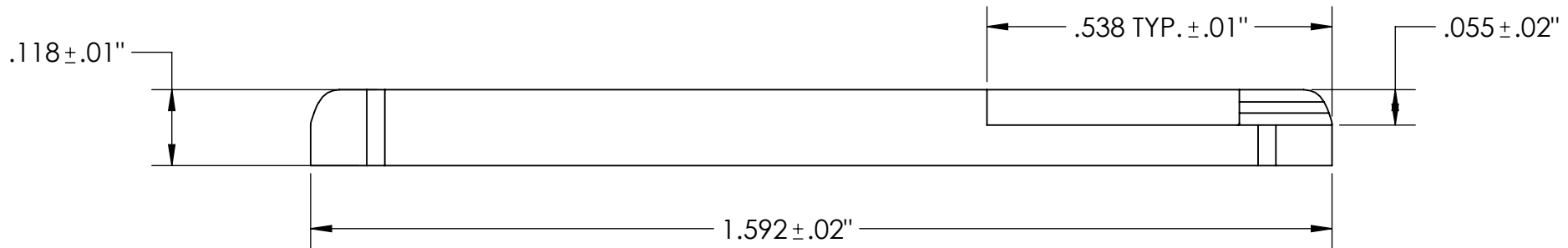
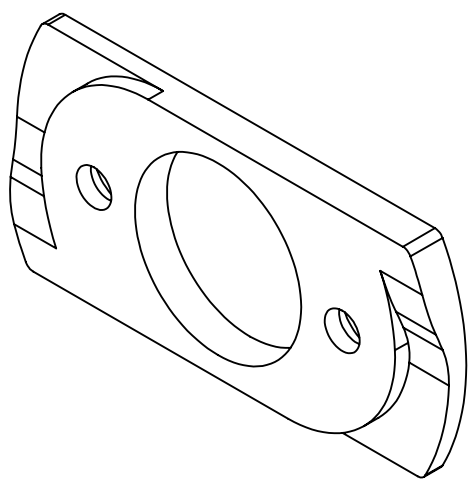
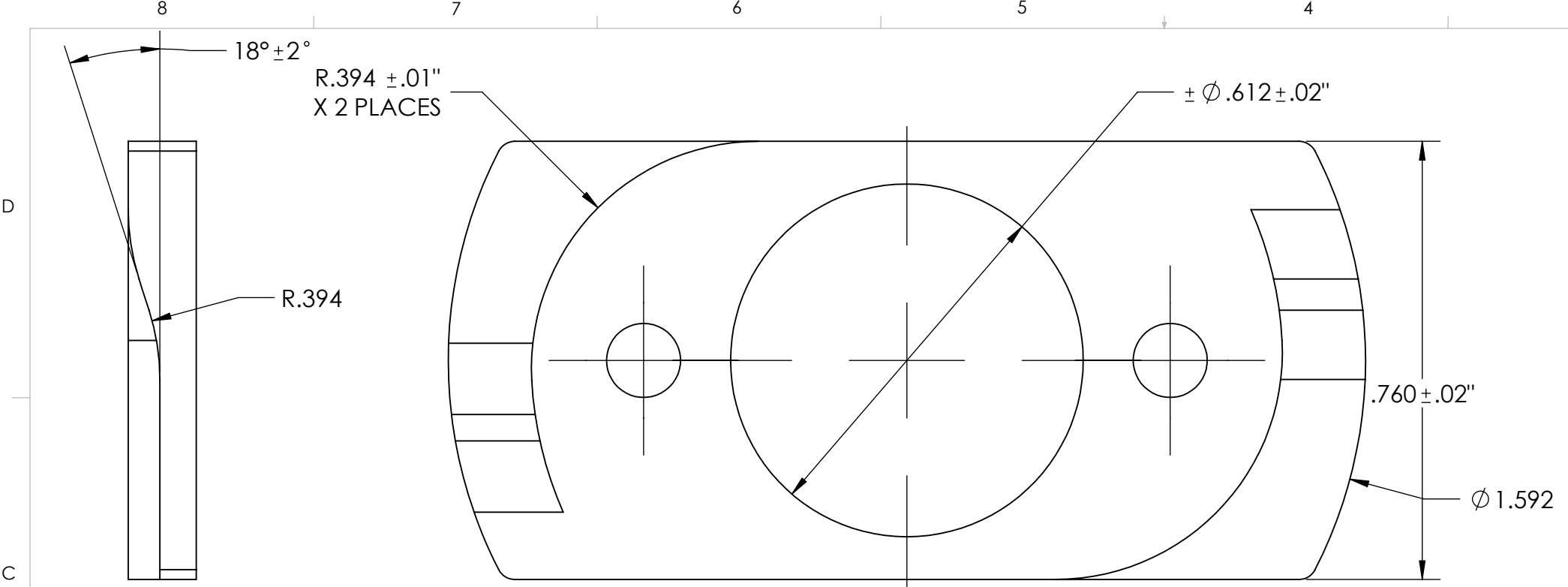

- NOTES:
1. REFER TO 3D CAD FILE 1116-01-106_PO
 2. MATERIAL:CRS STEEL
 3. FINISH : POLISH #4
 4. REMOVE ALL SHARP EDGES AND BURS

UNLESS OTHERWISE SPECIFIED:
 DIMENSIONS ARE IN: INCHES
 TOLERANCES: .XX: ± 0.03
 .XXX: ± 0.005
 ANGULAR: .X°: 1°
 .XX°: 0.5°
 BREAK EDGES: .005 - .020
 FILLETS: .005 - .020
 SUFACE FINISH:
 GEOMETRIC TOLERANCING
 PER: ASME Y14.5 -2009
 MATERIAL: SEE DRAWING NOTES
 FINISH: SEE DRAWING NOTES
 DO NOT SCALE DRAWING

	NAME	DATE
DRAWN	TC	7/26/16
CHECKED	RJB	7/26/16
COMMENTS:		

REF. NUMBER: SN0436

SupplyNet 706 EXECUTIVE BLVD.
SUITE B
VALLEY COTTAGE, NY 10989

TITLE:
MBITR STEEL TAB

SIZE	DWG. NO.	REV
B	1116-01-106	A

CAGE CODE: 1HJX9 SCALE: NA WEIGHT: SHEET 1 OF 1