

REVISIONS				
EC #	REV.	DESCRIPTION	DATE	APPROVED
-	A	INITIAL RELEASE	5/1/2007	RB
-	B	CHANGED WIRE RUN LIST	6/3/2009	RB

NOTES:

1. REPLACE 8 PIN DIN WITH BA5590-F FEMALE CONNECTOR AND KEEP AS MUCH OF EXISTING CABLE AS POSSIBLE.
2. GOLD PINS ARE RATED AT 10AMPS EACH.

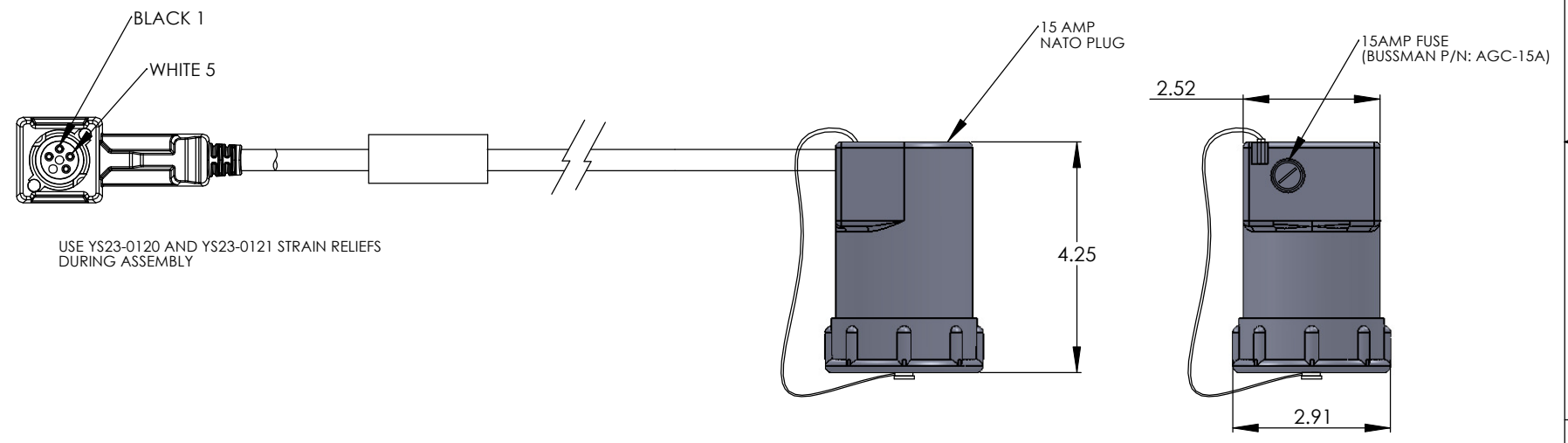
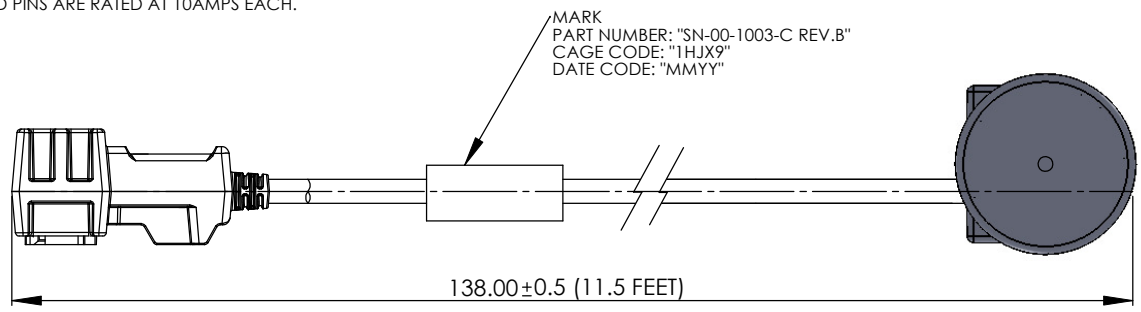

BA5590 (FEMALE)	WIRE COLORS	15 AMP NATO PLUG
1	BLACK	(-) GROUND
5	WHITE	(+) 24V

ⓑ

UNLESS OTHERWISE SPECIFIED:		NAME	DATE	614 CORPORATE WAY SUITE 8M VALLEY COTTAGE, NY 10980 CAGE CODE: 1HJX9	
DIMENSIONS ARE IN: INCHES		DRAWN	DD	06/03/09	TITLE: 15 AMP NATO PLUG WITH BA5590 FEMALE CONNECTOR
TOLERANCES:		CHECKED	RB	06/03/09	
.XX: ± .01 .XXX: ± .005		COMMENTS:			
ANGULAR: .X° .XX°		PROPRIETARY AND CONFIDENTIAL THE INFORMATION CONTAINED IN THIS DRAWING IS THE SOLE PROPERTY OF <INSERT COMPANY NAME HERE>. ANY REPRODUCTION IN PART OR AS A WHOLE WITHOUT THE WRITTEN PERMISSION OF <INSERT COMPANY NAME HERE> IS PROHIBITED.			SIZE B
INTERPRET GEOMETRIC TOLERANCING PER:					DWG. NO. SN-00-1003-C
MATERIAL SEE ABOVE					REV B
FINISH SEE ABOVE					SCALE: 1:1
DO NOT SCALE DRAWING					WEIGHT:
					SHEET 1 OF 1