

TABLE 1: WIRING		
P1	WIRE COLORS	SIGNAL
4	WHITE	422 OUT-
5	BLACK	422 OUT+
9	RED	422 IN-
10	GREEN	422 IN+
3, 13	BLUE	GND, SERIAL ENABLE
SHELL	SHIELD	

— TWISTED PAIR

— TWISTED PAIR

TABLE 2: WIRE LENGTH CHART		
PART NUMBER & PART MARKING	"-XX" DIMENSION	TOLERANCE (INCHES)
SN-07006B0057-02	24.00	+2.0", -0.0"
SN-07006B0057-03	36.00	+2.0", -0.0"
SN-07006B0057-04	48.00	+2.0", -0.0"
SN-07006B0057-05	60.00	+2.0", -0.0"
SN-07006B0057-07	84.00	+4.0", -0.0"
SN-07006B0057-10	120.00	+4.0", -0.0"
SN-07006B0057-12	144.00	+6.0", -0.0"
SN-07006B0057-20	240.00	+6.0", -0.0"

REV	DATE	DESCRIPTION OF CHANGE	ENG
A	5/14/2019	INITIAL RELEASE	LS

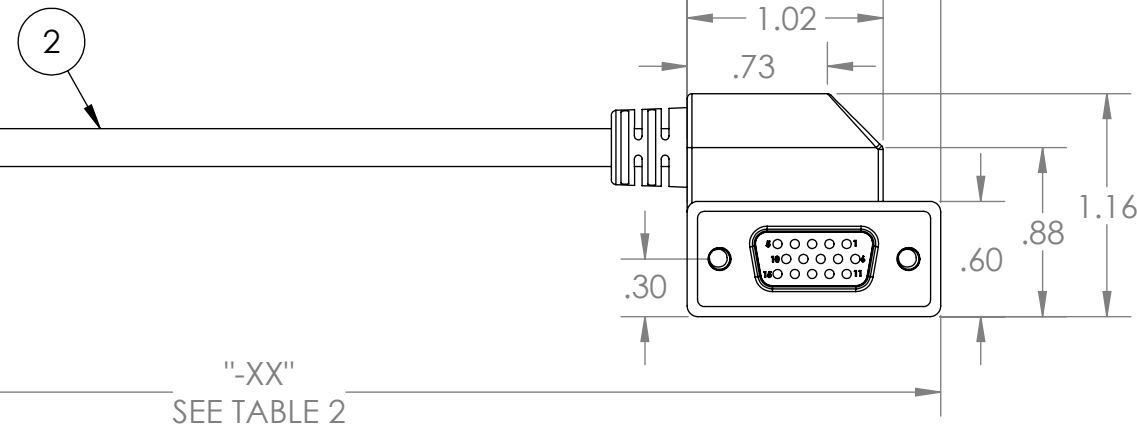
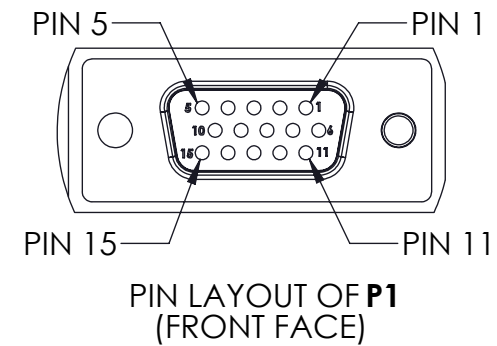
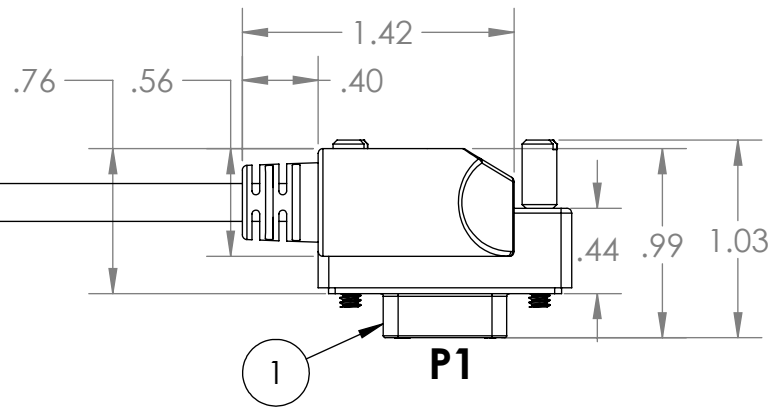
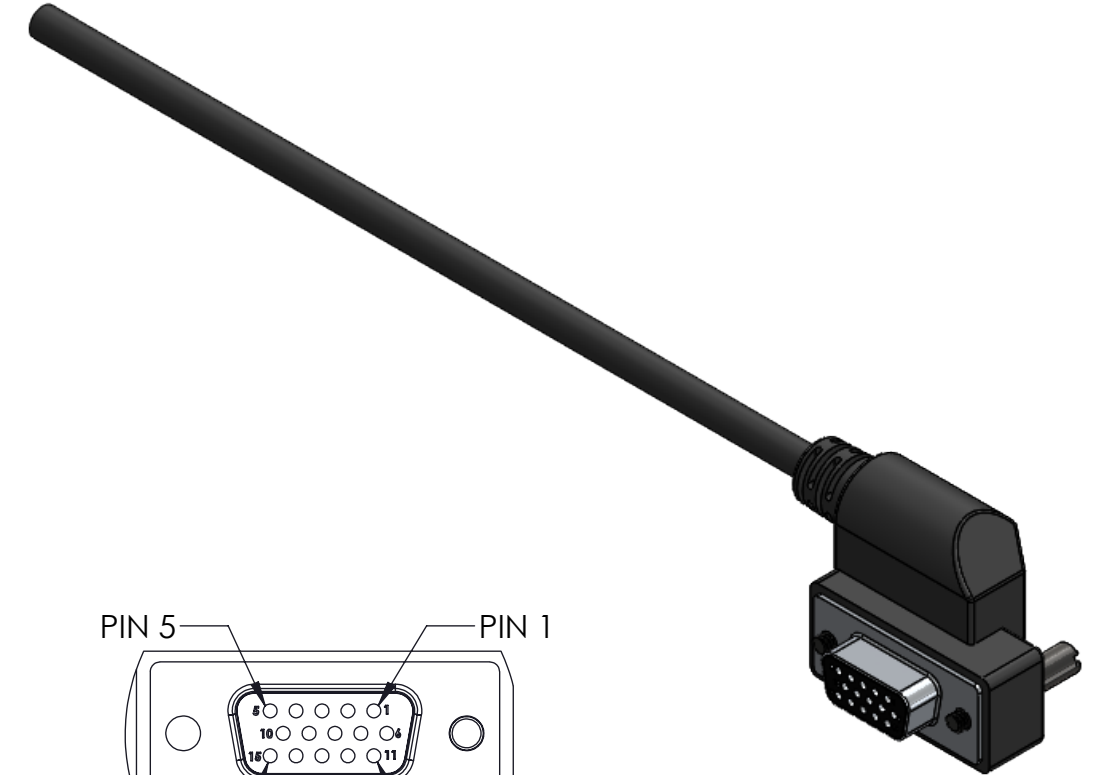

TABLE 3: BILL OF MATERIALS			
ITEM NO.	PART NO	QTY	NAME/DESCRIPTION
1	609-4045-ND	1	HD15 FEMALE CONNECTOR
2	TBD	XX	CABLE, 5C, 2 TWISTED PAIRS

NOTES:

- SOLDERING IAW IPC-J-STD-001 CLASS II AS APPLICABLE.
- WIRE ACCORDING TO TABLE 1.
- CABLE LENGTH IS TO BE ACCORDING TO PO AND TABLE 2.
- CABLE ASSEMBLIES TO BE 100% TESTED FOR CONTINUITY AND SHORTS.
- COMPLETED ASSEMBLIES SHALL BE PLACED IN A ZIPPER POLY-BAG. PLACE A LABEL ON THE BAG THAT CONTAINS THE FOLLOWING INFORMATION:

P/N: SN-07006B0057-XX (-XX PER PO)
CAGE CODE: 1HJX9
MFD: MM/YY (MM = MONTH MANUFACTURED, YY = LAST 2 DIGITS OF YEAR MANUFACTURED)

UNLESS OTHERWISE SPECIFIED:		NAME	DATE	REF. NUMBER: SN0639
DIMENSIONS ARE IN: INCHES		DRAWN	LS	
TOLERANCES: .XX: ± 0.03		CHECKED	RB	TITLE:
.XXX: ± 0.005		COMMENTS:		CABLE ASSEMBLY, PIGTAIL, DAGR SERIAL
ANGULAR: .X°: 1°		PROPRIETARY AND CONFIDENTIAL THE INFORMATION CONTAINED IN THIS DRAWING IS THE SOLE PROPERTY OF SUPPLYNET, INC. ANY REPRODUCTION IN PART OR AS A WHOLE WITHOUT THE WRITTEN PERMISSION OF SUPPLYNET INC. IS PROHIBITED.		
.XX°: 0.5°		SIZE DWG. NO. REV B SN-07006B0057-XX A		SCALE: NA WEIGHT: SHEET 1 OF 1
BREAK EDGES: .005 - .020		CAGE CODE: 1HJX9		
FILLETS: .005 - .020				
SURFACE FINISH:				
GEOMETRIC TOLERANCING PER: ASME Y14.5 -2009				
MATERIAL: SEE DRAWING NOTES				
FINISH: SEE DRAWING NOTES				
DO NOT SCALE DRAWING				