

TABLE 1: WIRE RUN		
P1	WIRE COLOR	P2
2	BROWN	2
5	BLACK	5
6	WHITE	6
7	GREEN	7
10	BLUE	10
12	RED	12
SHELL	SHIELD	SHELL

TWISTED PAIR

**CABLE SPECS:**

- A. COPPER 22 AWG SINGLE.
  - TEMPERATURE RATING: -30°C TO +150°C
  - INSULATION: FEP
  - COLORS: RED, BROWN, BLUE, AND BLACK
- B. 26 AWG, USB 2.0 COMPLIANT, TWISTED PAIR WITH DRAIN
  - TEMPERATURE RATING: -30°C TO +150°C
  - IMPEDANCE: 90 ± 15 OHMS
  - INSULATION: FEP
  - BRAIDED SHIELD: 40 AWG, MIN 95% COVERAGE, TIN PLATED COPPER
  - COLORS: GREEN AND WHITE
- C. BRAIDED SHIELD: 40 AWG, MIN 85% COVERAGE, TIN PLATED COPPER
- D. JACKET
  - MATERIAL: SILICONE (J-210 OR EQUIV.)
  - COLOR: BLACK
  - OVERALL MAX DIAMETER: .185 ± .02
- E. CABLE FLEXIBILITY SHALL BE 6X THE FINISHED DIAMETER.

REVISIONS			
REV.	DESCRIPTION	DATE	ENG
A	INITLA REV.	4/27/2022	MOB

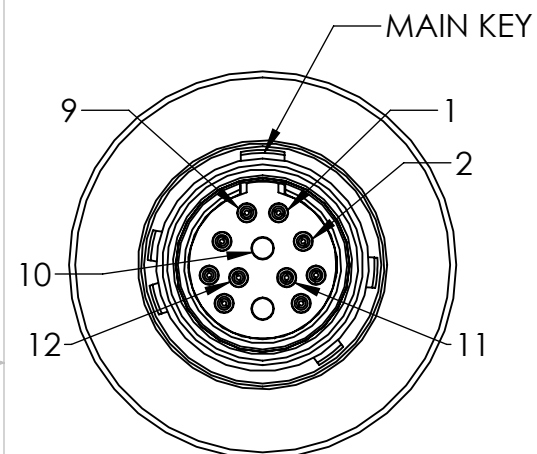

SECTION A-A  
P1 & P2 PINOUT  
SCALE 4 : 1

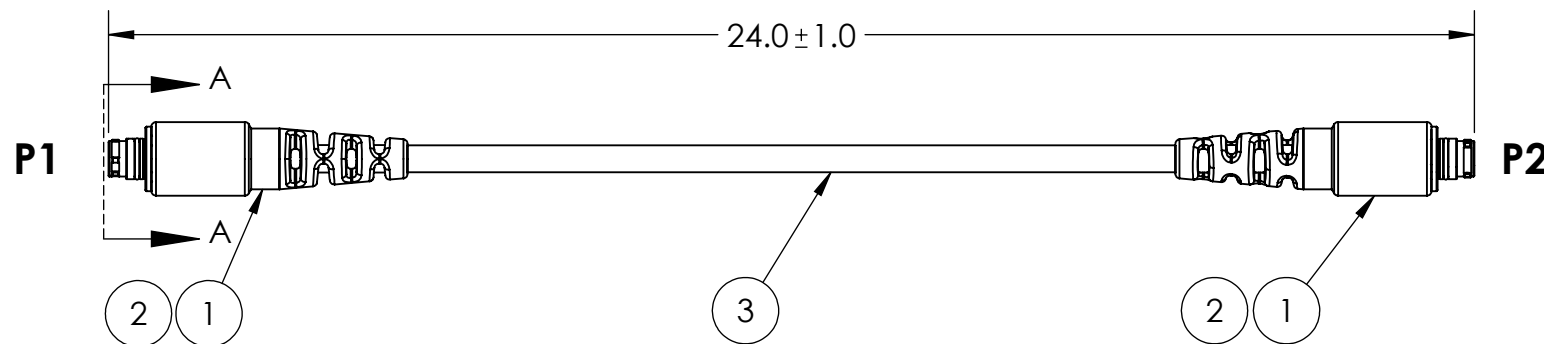

BILL OF MATERIALS			
ITEM NO.	PART NO.	QTY	NAME/DESCRIPTION
1	A10WAM-P12XM0-0000	1	ODU CIRC . CONN., PLUG, 12 POS., PIN CONTACTS
2	BE-04	2	BANDING CLAMP
3	BN226422FEPSSIL-BLK	AR	CABLE: 22/26 AWG, 6C, SHIELDED, PU JACKET, OD: .20 IN

**NOTES:**

1. WIRING SHALL BE DONE IN ACCORDANCE WITH TABLE 1 WIRE RUN LIST.
2. TWISTED PAIR SHALL BE USB 2.0 COMPLIANT; 26 AWG, SHIELDED, 90 OHM DIFFERENTIAL.
3. SOLDERING: IAW IPC-J-STD-001 CLASS 2 AS APPLICABLE
4. ASSEMBLY TO BE 100% TESTED FOR SHORTS, CONTINUITY, AND JACKET RESISTANCE (100V @ 100MOHM MIN.)
5. IDENTIFICATION: BAG AND IDENTIFY ON THE PACKAGING THE FOLLOWING INFORMATION FOR EACH PART DELIVERED.  
**PN: SN-2009 REV. X (REV MARKING PER PO)**  
**CAGE CODE: 1HJX9**  
**MFD: MM/YY**
6. MANUFACTURE AND INSPECT IAW IPC/WHMA A-620 CLASS 2.

UNLESS OTHERWISE SPECIFIED:	NAME	DATE
DIMENSIONS ARE IN: INCHES	DRAWN	MOB 04/27/22
TOLERANCES: .XX: ± 0.03	CHECKED	RB 04/27/22
.XXX: ± 0.005	COMMENTS:	
ANGULAR: .X°: 1°		
.XX*: 0.5°		
BREAK EDGES: .005 - .020		
FILLETS: .005 - .020		
SURFACE FINISH:		
GEOMETRIC TOLERANCING PER: ASME Y14.5 -2009		
MATERIAL: SEE DRAWING NOTES		
FINISH: SEE DRAWING NOTES		
DO NOT SCALE DRAWING		

REF. NUMBER: SN0715

**SupplyNet** 706 EXECUTIVE BLVD  
SUITE B  
VALLEY COTTAGE, NY 10989

TITLE: **DUAL ODU CABLE ASSEMBLY**

SIZE **B** DWG. NO. **SN-2009** REV **A**

SCALE: NA WEIGHT: SHEET 1 OF 1

**PROPRIETARY AND CONFIDENTIAL**  
THE INFORMATION CONTAINED IN THIS DRAWING IS THE SOLE PROPERTY OF SUPPLYNET, INC. ANY REPRODUCTION IN PART OR AS A WHOLE WITHOUT THE WRITTEN PERMISSION OF SUPPLYNET INC. IS PROHIBITED.

**CAGE CODE: 1HJX9**