

REV	DATE	DESCRIPTION OF CHANGE	ENG
C	12/30/16	CHANGED DIODE	LS

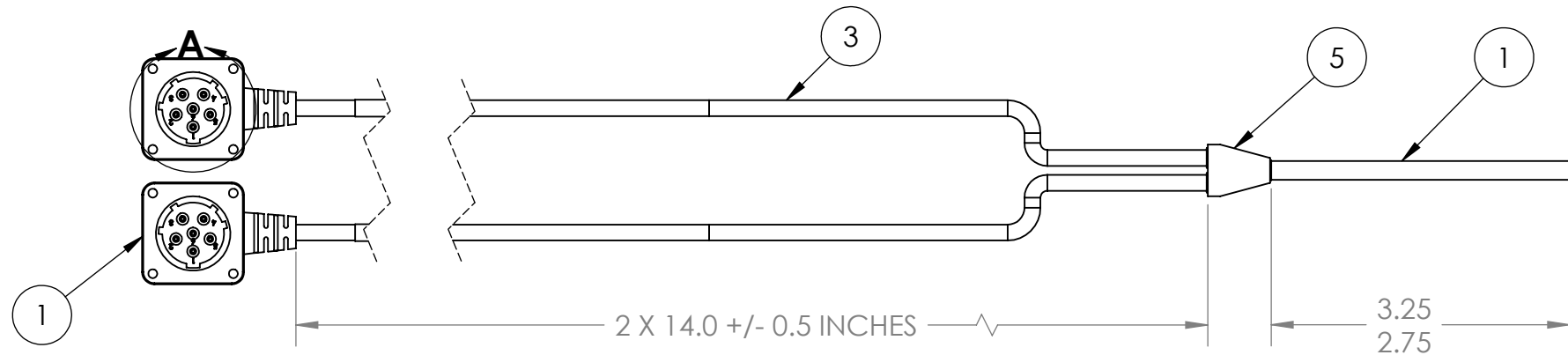
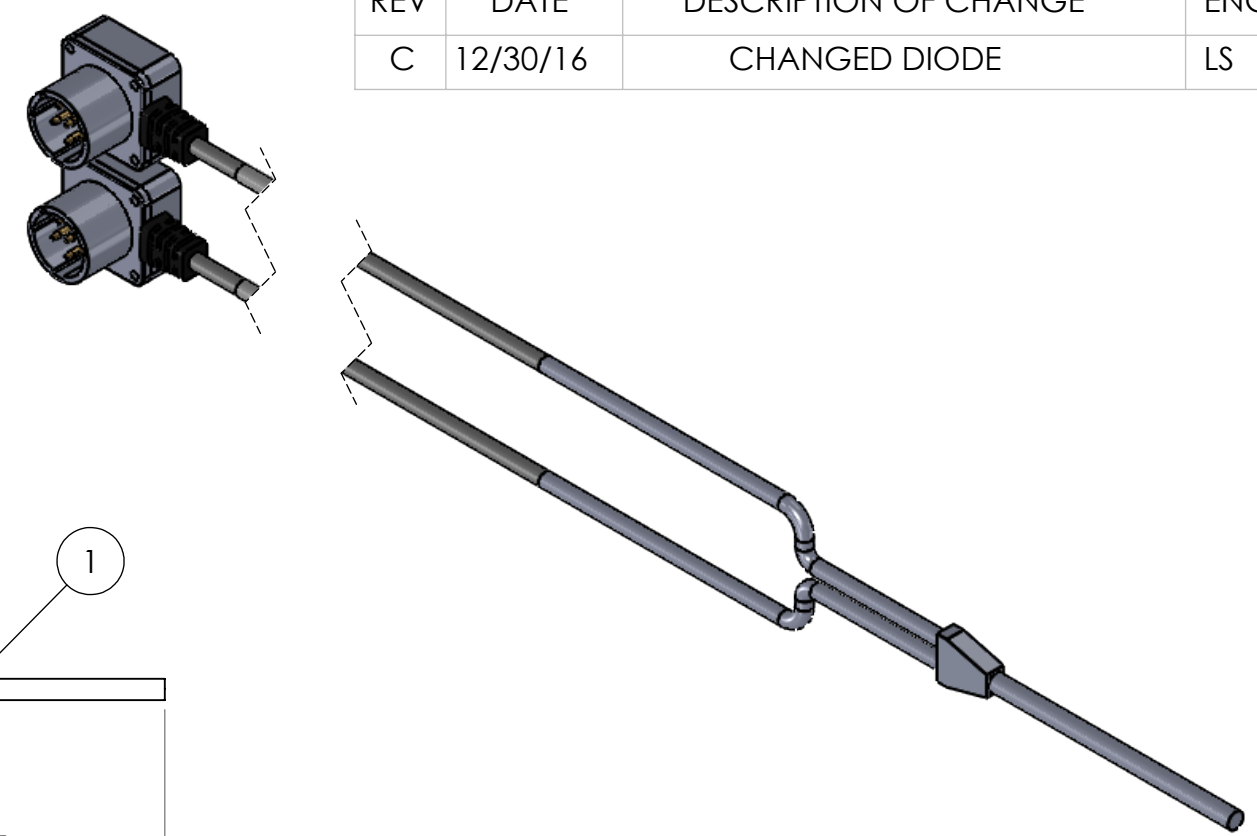
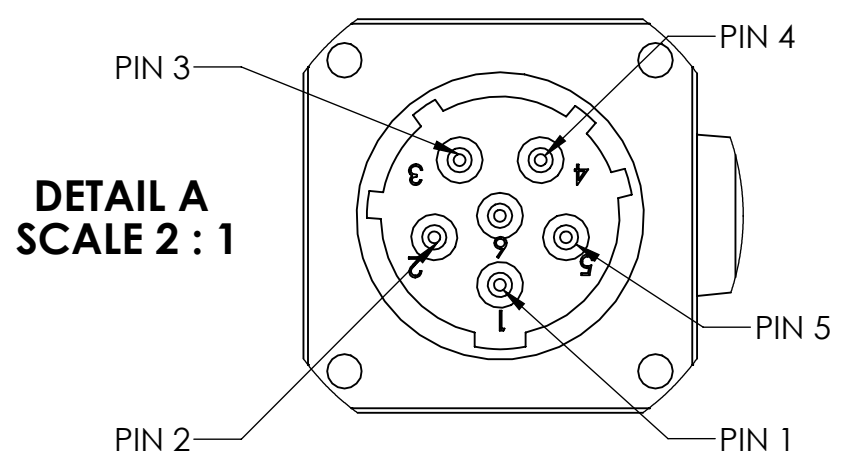
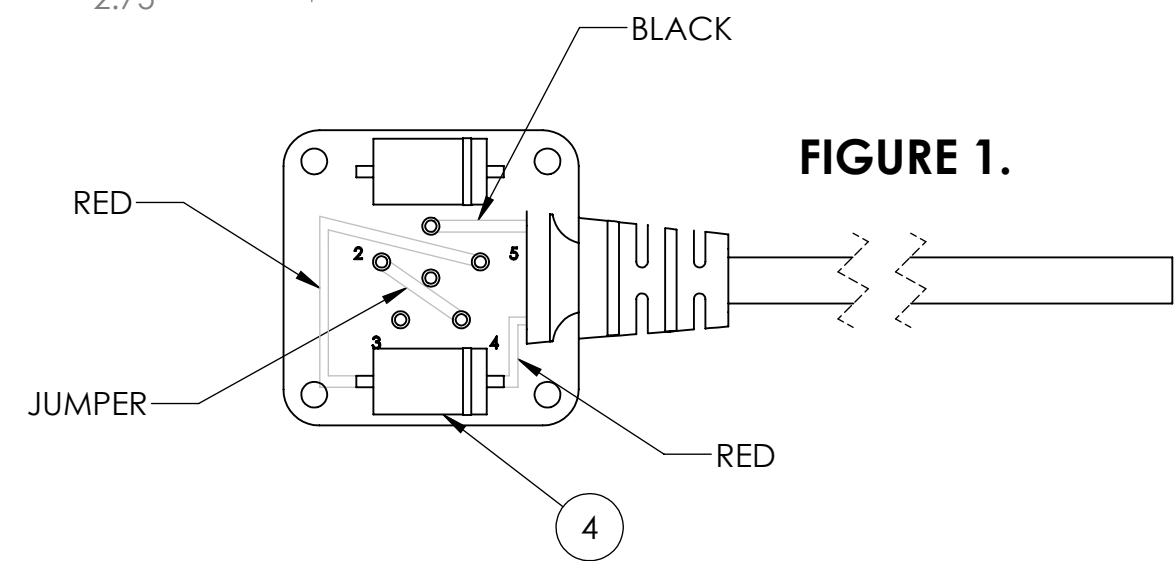

TABLE 1	
ITEM 4 WIRE COLOR	BA5590-MP PIN
BLACK	1
RED	5
	2 JUMPED TO 4

BILL OF MATERIALS				
ITEM NO.	PART NUMBER	QTY	NAME	COMMENTS
1		30"	18 AWG	2C CABLE. 5.0MM OD.
2	BA5590	2	BA-5590 MALE	CONNECTOR
3	UL1332 TEFLON	3"	20 AWG	2C CABLE. 4.6MM OD
4	SB1245	2	DIODE	45V, 12 AMP
5	YS14-0675	1	Y SPLITTER	



**NOTES:**

- CONNECT WIRING PER FIGURE 1 AND TABLE 1..
- SOLDERING IAW IPC-J-STD-001 CLASS II AS APPLICABLE.
- CABLE ASSEMBLIES TO BE 100% TESTED FOR CONTINUITY, SHORTS AND INSULATION RESISTANCE (250V @100MOHM MINIMUM)
- IDENTIFICATION: BAG AND IDENTIFY ON PACKAGING THE FOLLOWING INFORMATION FOR EACH PART DELIVERED. UOS PART MARKING ON THE WIRE IS PROHIBITED:  
**PN: SN-333 REV X (REV MARKING PER PO)**  
**CAGE CODE: 1HJX9**  
**DATE OF MFG: MM/YY**
- REFERENCE SUPPLYNET FILE NUMBER SN0244.
- MANUFACTURE AND INSPECT IAW IPC/WHMA A-620 CLASS 2.

UNLESS OTHERWISE SPECIFIED:  
 DIMENSIONS ARE IN: INCHES  
 TOLERANCES: .XX: ± 0.03  
 .XXX: ± 0.005  
 ANGULAR: .X°: 1°  
 .XX°: 0.5°  
 BREAK EDGES: .005 - .020  
 FILLETS: .005 - .020  
 SURFACE FINISH:  
 GEOMETRIC TOLERANCING PER: ASME Y14.5-2009  
 MATERIAL: SEE DRAWING NOTES  
 FINISH: SEE DRAWING NOTES  
 DO NOT SCALE DRAWING

	NAME	DATE
DRAWN	RJB	9/19/13
CHECKED	RJB	9/19/13
COMMENTS:		

**PROPRIETARY AND CONFIDENTIAL**  
 THE INFORMATION CONTAINED IN THIS DRAWING IS THE SOLE PROPERTY OF SUPPLYNET, INC. ANY REPRODUCTION IN PART OR AS A WHOLE WITHOUT THE WRITTEN PERMISSION OF SUPPLYNET INC. IS PROHIBITED.

**CAGE CODE: 1HJX9**

PART NUMBER: SN-333		
614 CORPORATE WAY SUITE 8M VALLEY COTTAGE, NY 10989		
TITLE: BA5590 2 WAY, 24V SPLITTER CABLE, UNTERMINATED		
SIZE <b>B</b>	DWG. NO. <b>SN-333</b>	REV <b>C</b>
SCALE: NA	WEIGHT:	SHEET 1 OF 1