

8 7 6 5 4 3 2 1

REVISIONS			
REV.	DESCRIPTION	DATE	ENG
A	INITIAL REV.	10/27/22	MOB

RADIO SIDE

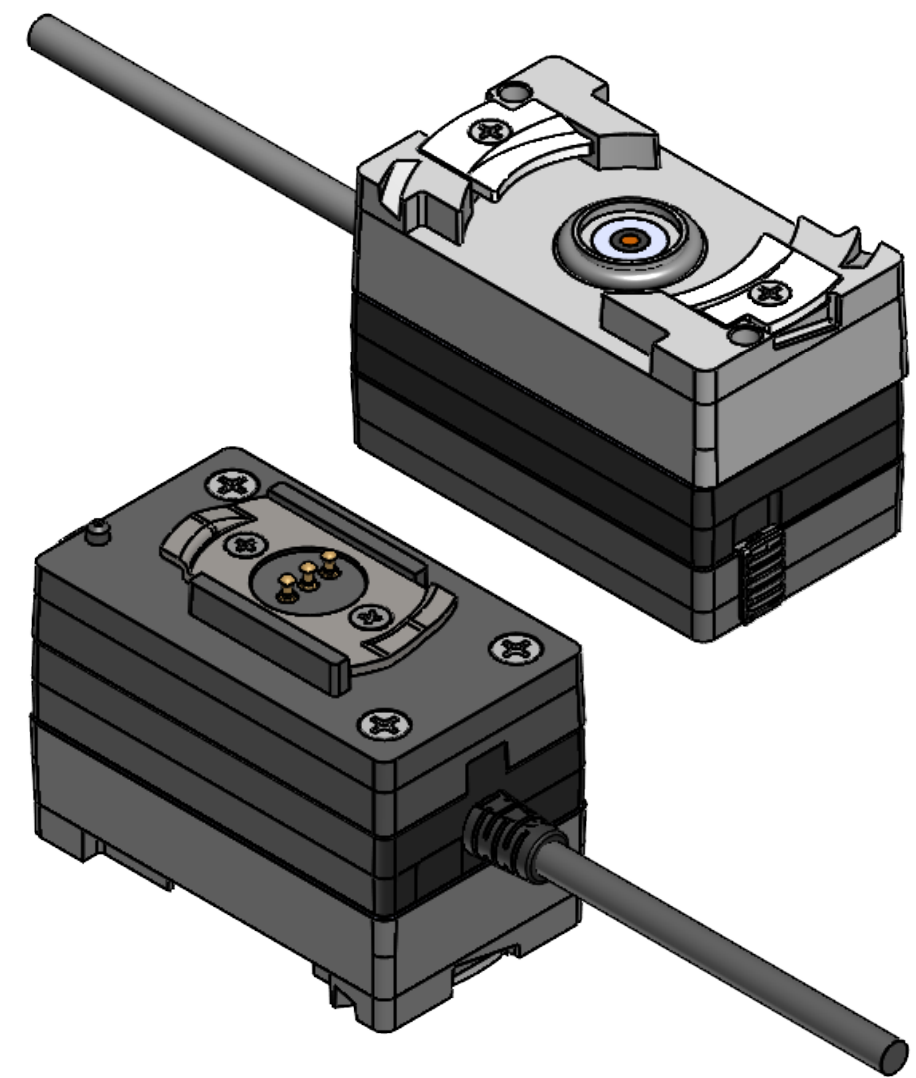
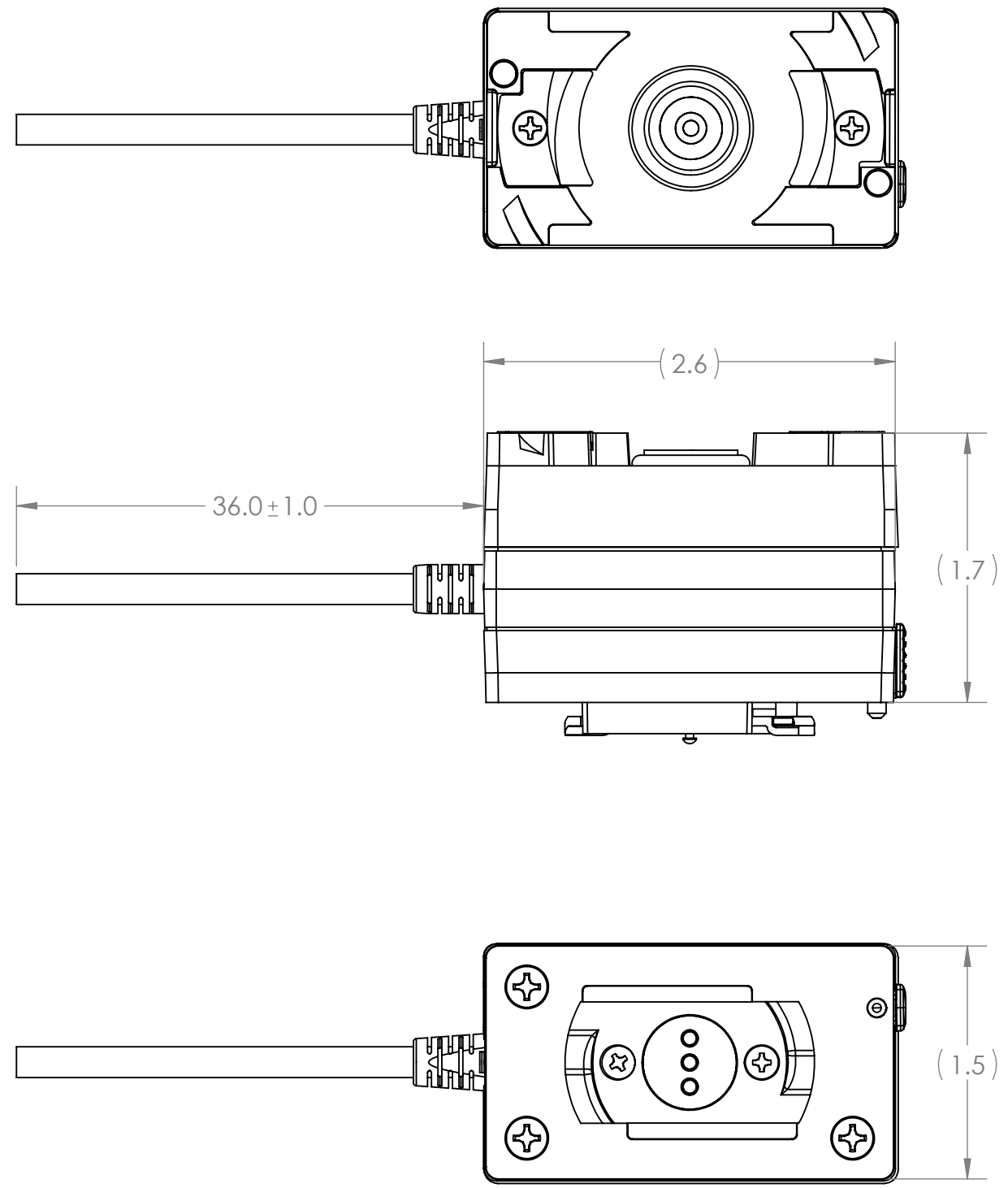

FINAL PRODUCT COLOR IS BLACK
GRAY SHOWN FOR CLARITY.

BATTERY SIDE

NOTES:
1. BOM AND EXPLODED VIEW ON SHEET 2 OF THIS DOCUMENT.

UNLESS OTHERWISE SPECIFIED:
DIMENSIONS ARE IN: INCHES
TOLERANCES: .XX: ± 0.03
.XXX: ± 0.005
ANGULAR: .X°: 1°
.XX°: 0.5°
BREAK EDGES: .005 - .020
FILLETS: .005 - .020
SURFACE FINISH:
GEOMETRIC TOLERANCING
PER: ASME Y14.5 -2009
MATERIAL: SEE DRAWING NOTES
FINISH: SEE DRAWING NOTES
DO NOT SCALE DRAWING

	NAME	DATE
DRAWN	MOB	10/27/22
CHECKED	RB	10/27/22
COMMENTS:		
PROPRIETARY AND CONFIDENTIAL		
THE INFORMATION CONTAINED IN THIS DRAWING IS THE SOLE PROPERTY OF SUPPLYNET, INC. ANY REPRODUCTION IN PART OR AS A WHOLE WITHOUT THE WRITTEN PERMISSION OF SUPPLYNET INC. IS PROHIBITED.		
CAGE CODE: 1HJX9		

REF. NUMBER: SN0370		
SupplyNet		706 EXECUTIVE BLVD SUITE B VALLEY COTTAGE, NY 10989
TITLE: AN/PRC-163 BATTERY WEDGE KIT		
SIZE B	DWG. NO. SN-832-163-KIT	REV A
SCALE: NA	WEIGHT:	SHEET 1 OF 2

8 7 6 5 4 3 2 1

8 7 6 5 4 3 2 1

D

C

B

A

D

C

B

A

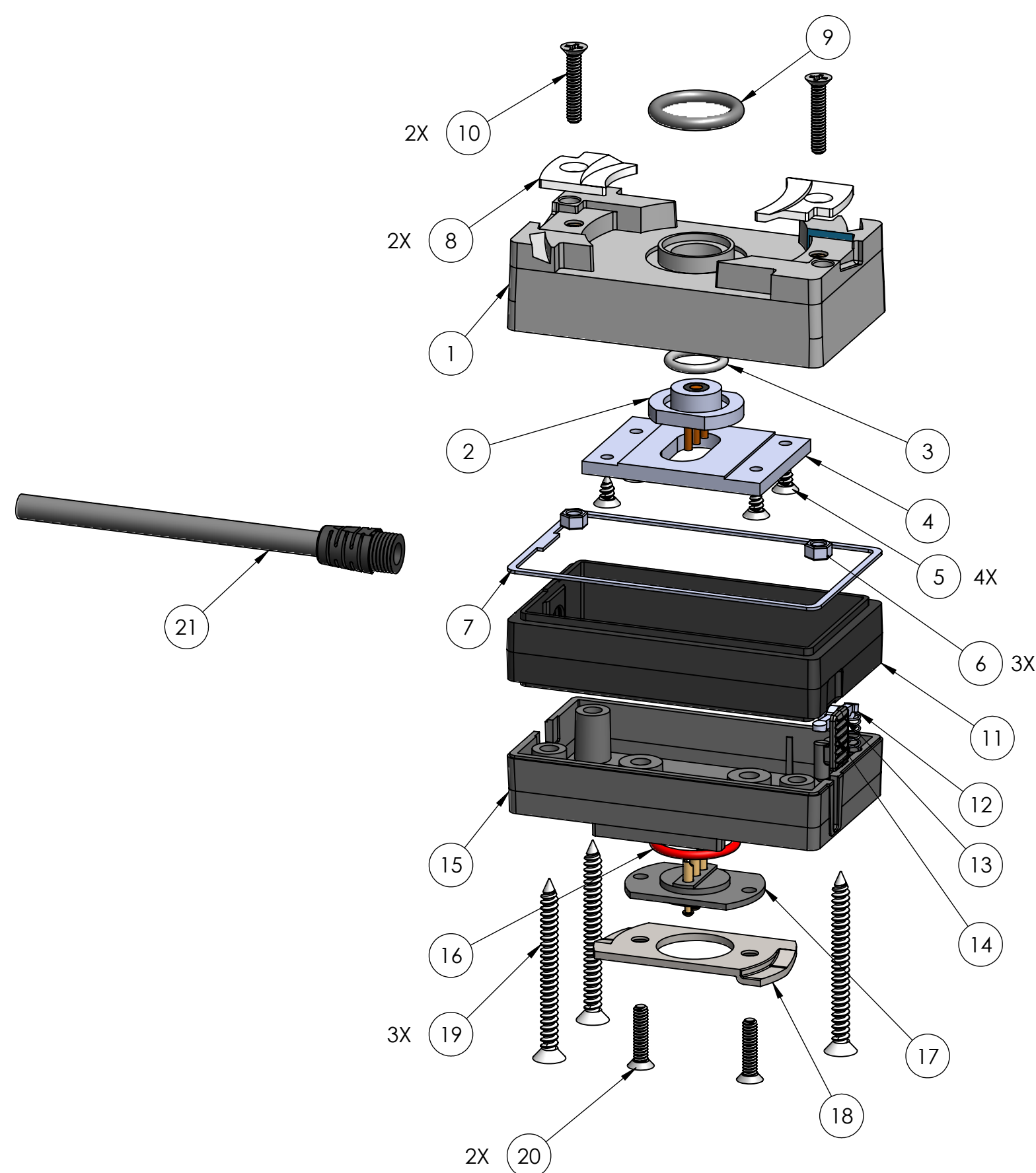

BILL OF MATERIALS			
ITEM NO.	PART NO.	QTY	NAME/DESCRIPTION
1	SN-PRC-163-1	1	TOP COVER
2	SN-PRC-163-ASSY	1	CONTACT ASSEMBLY
3	9452K210	1	CONTACT O-RING
4	SN-PRC-163-3	1	INSULATOR PLATE
5	90198A100	4	#4x1/4 FLAT HEAD SCREW
6	90730A005	3	4-40 HEX NUT
7	SN-PRC-163-5	1	SEALING GASKET
8	STEEL-TAB	2	STEEL GROUND TABS
9	9452K25	1	O-RING FACE SEAL
10	67566521	2	4-40 FLAT HEAD PHILLIPS SCREW, SS, 3/8"
11	SN-1034-8MM-2	1	SPACER, M8x1.25 THREADED CABLE EXIT, SINGLE TAB
12	FE-411-04C	1	ROCKER ARM, LOCKING BUTTON
13	C0120-014-0500-M	1	SPRING, LOCKING BUTTON
14	FF-611-05A	1	LOCKING BUTTON
15	111-01-101-HOLES	1	BOTTOM COVER, 3 HOLES
16	571-063-R70BT	1	RED TEFLON COATED BUNA O-RING
17	1116-01-105	1	POGO PIN ASSEMBLY
18	1116-01-106-STAMP	1	STAMPED GROUND BAR
19	90033A168	3	PHILLIPS FLAT HEAD SCREW, BLACK OXIDE, 1- 1/2" LONG
20	91099A169	2	4-40 5/8" LONG SS, FLAT HEAD PHILLIPS SCREW
21	SN-359-T-X	1	AWG 20, 4C + DRAIN, FOIL SHIELD, WITH M8x1.25 THREADED STRAIN RELIEF

PROPRIETARY AND CONFIDENTIAL
 THE INFORMATION CONTAINED IN THIS DRAWING IS THE SOLE PROPERTY OF SUPPLYNET, INC. ANY REPRODUCTION IN PART OR AS A WHOLE WITHOUT THE WRITTEN PERMISSION OF SUPPLYNET INC. IS PROHIBITED.

DO NOT SCALE DRAWING

CAGE CODE: 1HJX9

REF. NUMBER: SN0370

SupplyNet 706 EXECUTIVE BLVD
 SUITE B
 VALLEY COTTAGE, NY 10989

TITLE:
AN/PRC-163 BATTERY WEDGE KIT

SIZE B	DWG. NO. SN-832-163-KIT	REV A
------------------	-----------------------------------	-----------------

SCALE: NA WEIGHT: SHEET 2 OF 2

8 7 6 5 4 3 2 1