

REVISIONS			
REV.	DESCRIPTION	DATE	ENG
D	REDRAWN WITHOUT CHANGE: FAMILY DRAWING BROKEN OUT INTO SEPARATE DRAWINGS.	10/19/22	MOB

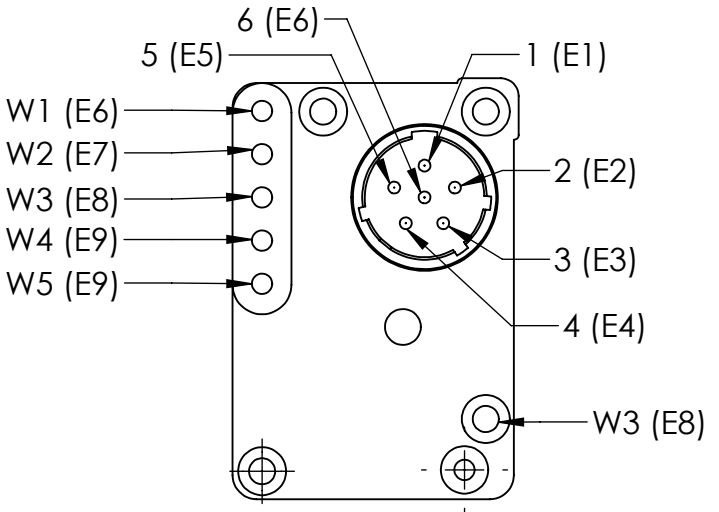

CONNECTOR PINOUT  
PCB PINS IN PARENTHESES  
(MATING FACE VIEW)

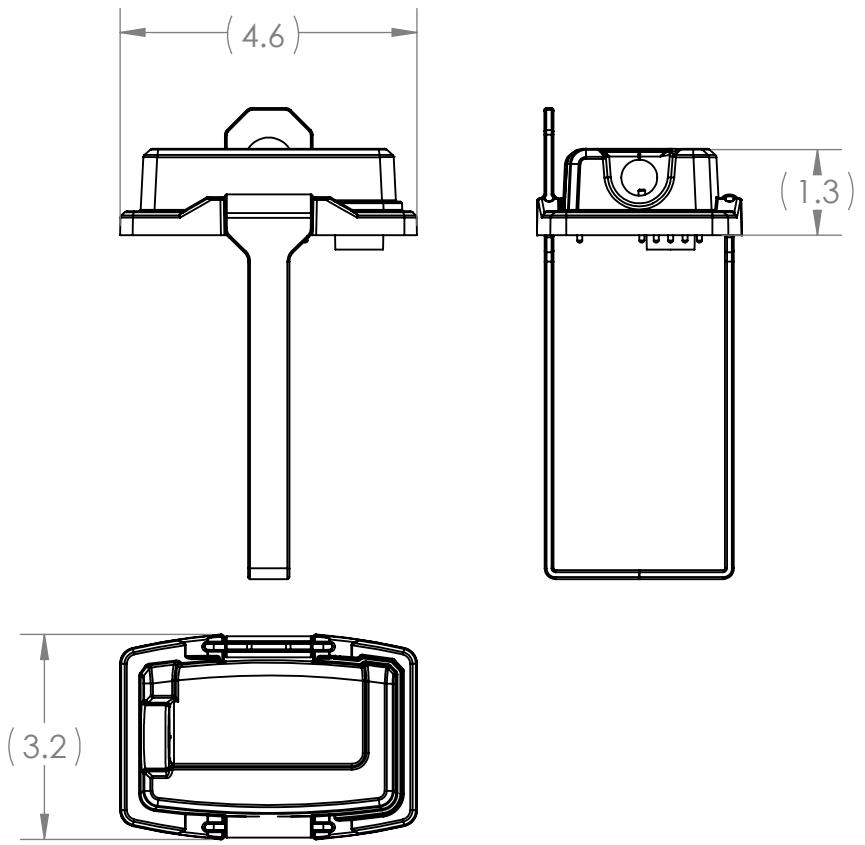

IT IS RECOMMENDED TO RAISE THE POGO PIN SHELLS BY .10 INCHES FOR BETTER CONTACT WITH BATTERY SMBUS.  
NOTE: POGO PINS WILL STILL CONTACT SMBUS IF NOT RAISED.

BILL OF MATERIALS.				
ITEM NUMBER	PART NUMBER	QTY	NAME	COMMENTS
1	SN0132-T	1	BATTERY COVER	9/16-24 Threaded Hole
2	SN0008-1	1	PCB	
3	SN0117-3-A	1	CONNECTOR	4 KEYWAY, N PIN LENGTH
4	SN0009	6	POGO PINS	
5	SN0133-1	1	SPACER PLATE	
6	SN0012	8	FLAT HEAD 5/8" SCREW	5/8" SCREW (BLACK)
7	SN0270-WT	1	GASKET	PERIMETER SEAL
8	SN0136	1	STRAP ASSEMBLY	

NOTES:  
1. FOR 12V WIRE SECTION A IN PARALLEL WITH SECTION B.  
2. FOR 24V WIRE SECTION A IN SERIES WITH SECTION B.  
3. BATTERY NOT INCLUDED.

UNLESS OTHERWISE SPECIFIED:  
DIMENSIONS ARE IN: INCHES  
TOLERANCES: .XX: ± 0.03  
.XXX: ± 0.005  
ANGULAR: .X°: 1°  
.XX°: 0.5°  
BREAK EDGES: .005 - .020  
FILLETS: .005 - .020  
SURFACE FINISH:  
GEOMETRIC TOLERANCING PER: ASME Y14.5-2009  
MATERIAL: SEE DRAWING NOTES  
FINISH: SEE DRAWING NOTES  
DO NOT SCALE DRAWING

NAME	DATE
DRAWN MM	09/17/22
CHECKED MOB	09/17/22
COMMENTS:	

REF. NUMBER: SN0405

**SupplyNet** 706 EXECUTIVE BLVD  
SUITE B  
VALLEY COTTAGE, NY 10989

TITLE: **BB2590 WATER-TIGHT BATTERY COVER W/ SMBUS, KIT**

SIZE <b>B</b>	DWG. NO. <b>SN-404-KIT</b>	REV <b>D</b>
---------------	----------------------------	--------------

CAGE CODE: 1HJX9    SCALE: NA    WEIGHT:    SHEET 1 OF 1

