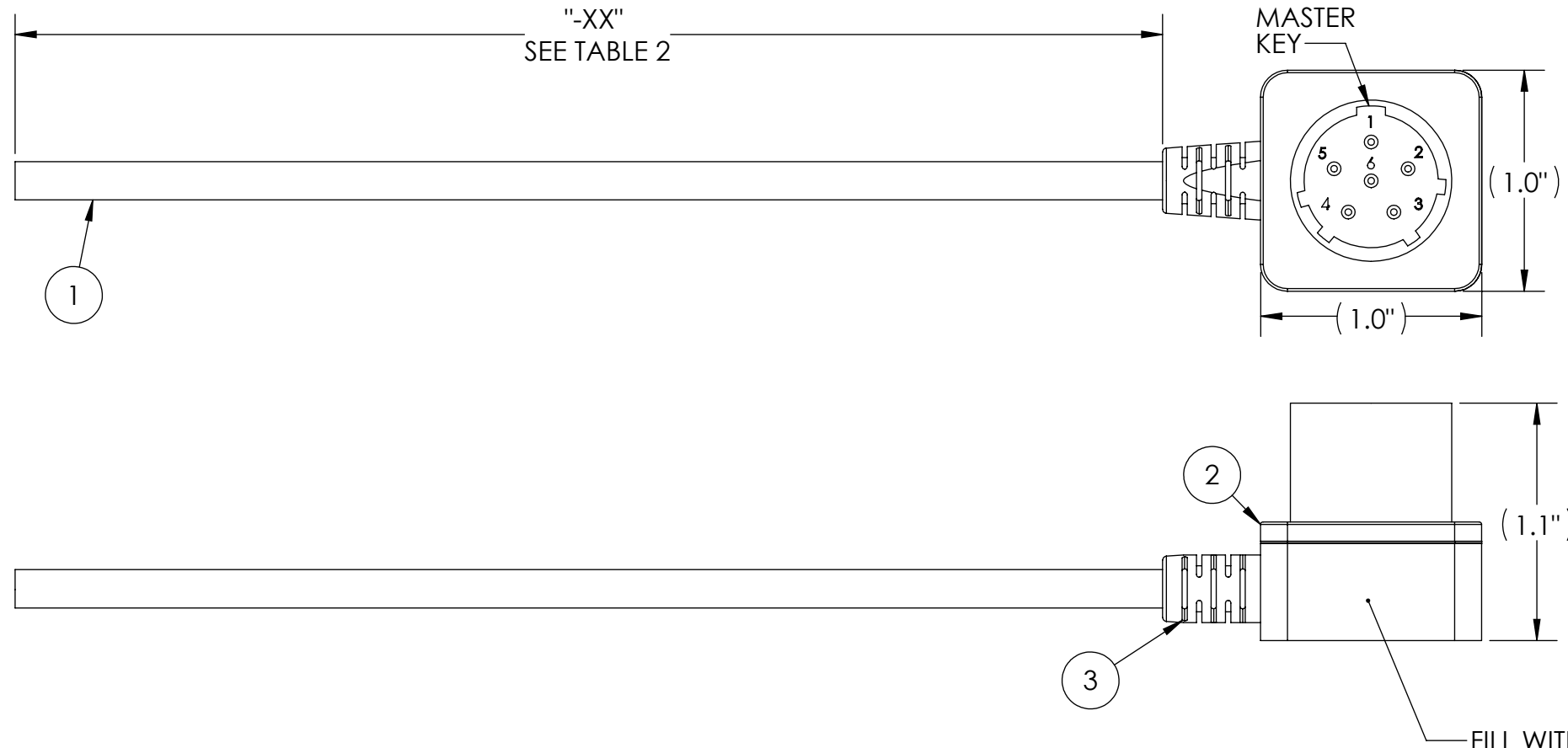
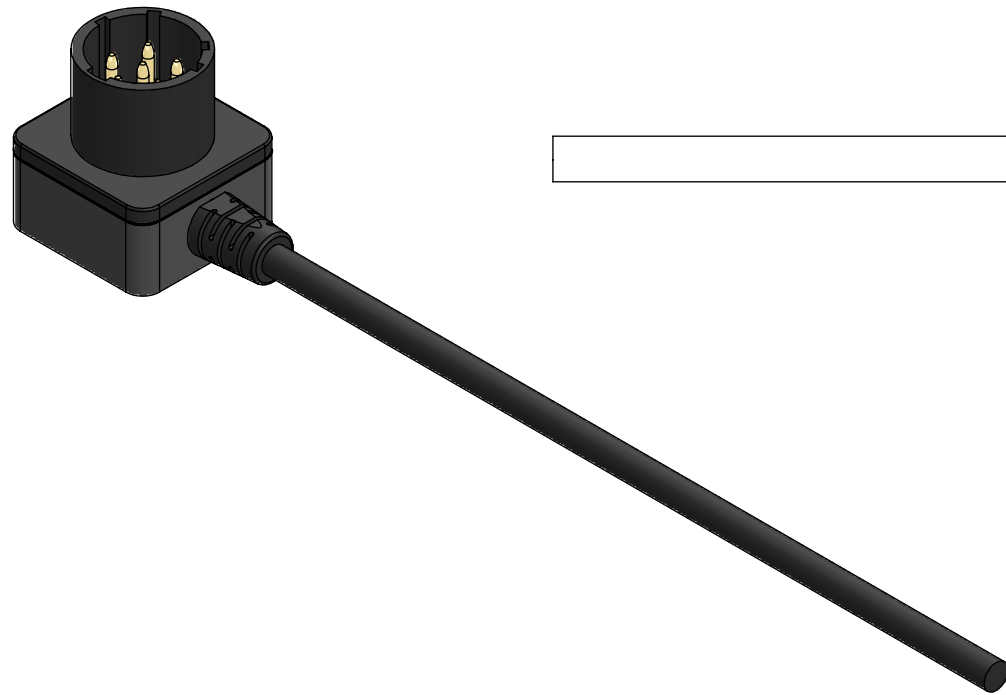

TABLE 1: WIRE RUN LIST	
PIN	WIRE COLORS
5	RED
1	BLACK
2, 4	JUMPER WIRE

*JUMP PINS 2 & 4

TABLE 2: WIRE LENGTH CHART		
PART NUMBER & PART MARKING	"-XX" DIMENSION (INCHES)	TOLERANCE (INCHES)
191004F-01-ND	12	+1.0", -0.0"
191004F-02-ND	24	+2.0", -0.0"
191004F-03-ND	36	+2.0", -0.0"
191004F-04-ND	48	+2.0", -0.0"
191004F-05-ND	60	+2.0", -0.0"
191004F-06-ND	72	+4.0", -0.0"
191004F-08-ND	96	+4.0", -0.0"
191004F-10-ND	120	+4.0", -0.0"
191004F-12-ND	144	+6.0", -0.0"
191004F-15-ND	216	+6.0", -0.0"
191004F-20-ND	240	+6.0", -0.0"



REVISIONS			
REV.	DESCRIPTION	DATE	APPROVED
I	REMOVED PCB FROM BOM, UPDATED WIRE RUN LIST.	1/15/2021	MOB
J	CHANGED ITEM NO. 1 PN, ADDED HI-POT NOTES	3/29/2022	MOB

TABLE 2: BILL OF MATERIALS			
ITEM NO.	PART NO	QTY	NAME/DESCRIPTION
1	202C-U07A	XX	CABLE, 2C, AWG 20, PU JACKET, 4.6MM OD
2	CONN-BA5590-MT	1	Male BA5590 with Threaded Backshell
3	SR:0024	1	THREADED STRAIN RELIEF

NOTES:

1. WIRE FUNCTION: SEE TABLE 1 WIRE RUN LIST.
2. CABLE LENGTH: "-XX" AS PER PO.
3. ASSEMBLY TO BE 100% TESTED FOR CONTINUITY, SHORTS, AND JACKET RESISTANCE.(250V @ 100MOHM MIN)
4. SOLDERING: IAW IPC-J-STD-001 CLASS II AS APPLICABLE.
5. IDENTIFICATION: BAG AND IDENTIFY ON PACKAGING THE FOLLOWING INFORMATION FOR EACH PART DELIVERED.
PN: 191004F-XX-ND REV. X ("-XX" & REV AS PER PO)
CAGE CODE: 1HJX9
MFD: MM/YY
6. REFERENCE SUPPLYNET FILE NUMBER SN0617.
7. MANUFACTURE AND INSPECT IAW IPC/WHMA A-620 CLASS 2.

UNLESS OTHERWISE SPECIFIED:		NAME	DATE	REF. NUMBER: SN0617
DIMENSIONS ARE IN: INCHES		DRAWN	LS	3/29/2019
TOLERANCES: .XX: ± 0.03		CHECKED	RB	3/29/2019
.XXX: ± 0.005		COMMENTS:		
ANGULAR: .X*: 1°		PROPRIETARY AND CONFIDENTIAL THE INFORMATION CONTAINED IN THIS DRAWING IS THE SOLE PROPERTY OF SUPPLYNET, INC. ANY REPRODUCTION IN PART OR AS A WHOLE WITHOUT THE WRITTEN PERMISSION OF SUPPLYNET INC. IS PROHIBITED.		
BREAK EDGES: .005 - .020				
FILLETS: .005 - .020				
SURFACE FINISH:				
GEOMETRIC TOLERANCING PER: ASME Y14.5 -2009		TITLE: BB-2590 BATTERY CABLE WITH POLYURETHANE JACKET, 24V, VARIABLE LENGTH		
MATERIAL: SEE DRAWING NOTES		SIZE	DWG. NO.	REV
FINISH: SEE DRAWING NOTES		B	191004F-XX-ND	J
DO NOT SCALE DRAWING		CAGE CODE: 1HJX9		SCALE: NA WEIGHT: SHEET 1 OF 1