

| REVISIONS |             |            |          |
|-----------|-------------|------------|----------|
| REV.      | DESCRIPTION | DATE       | APPROVED |
| A         | RELEASE     | 11/21/2023 | CWA      |

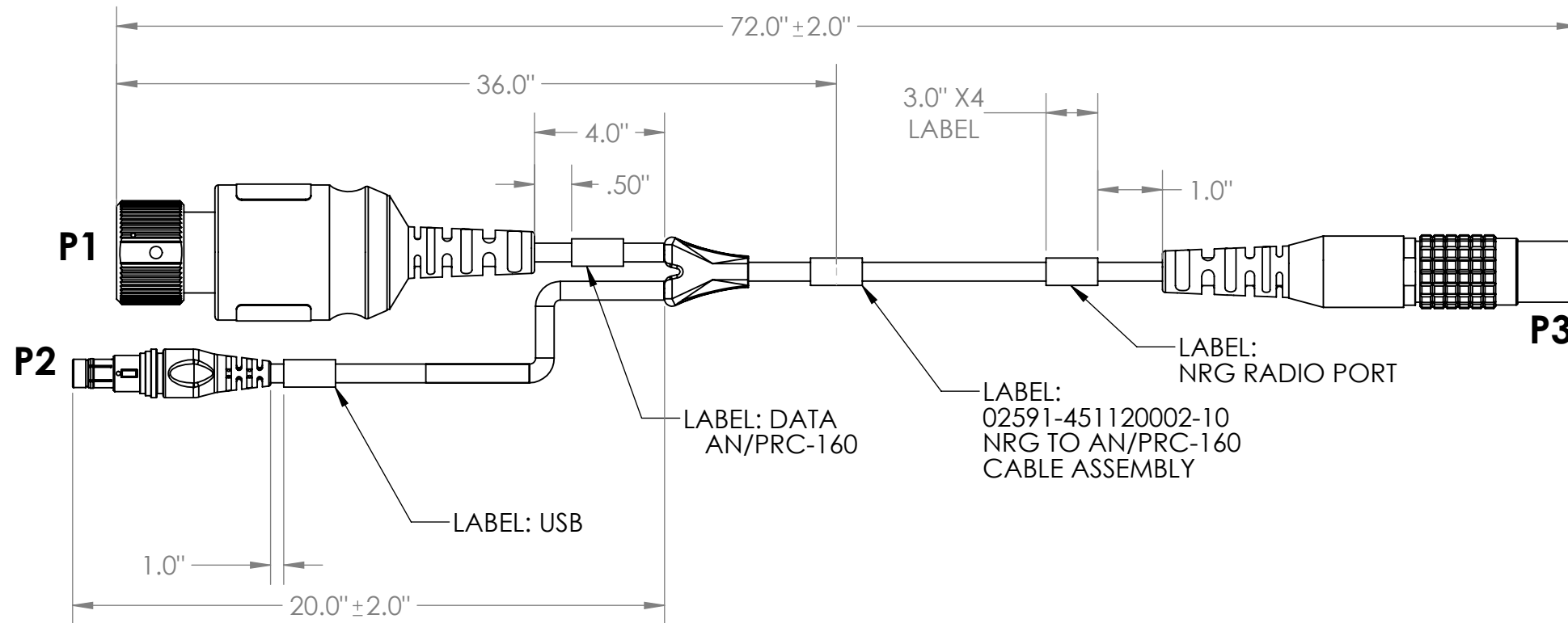
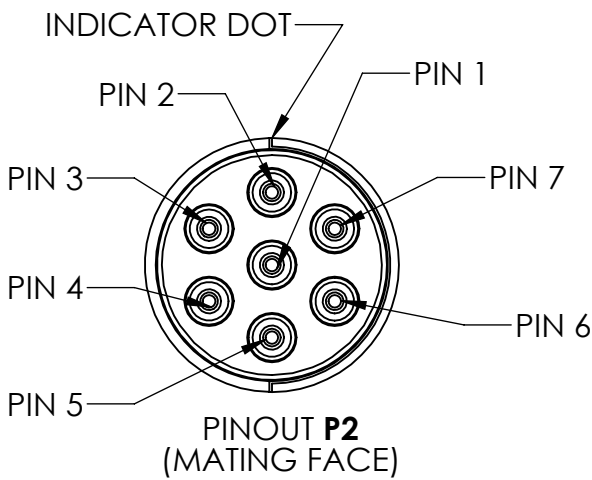
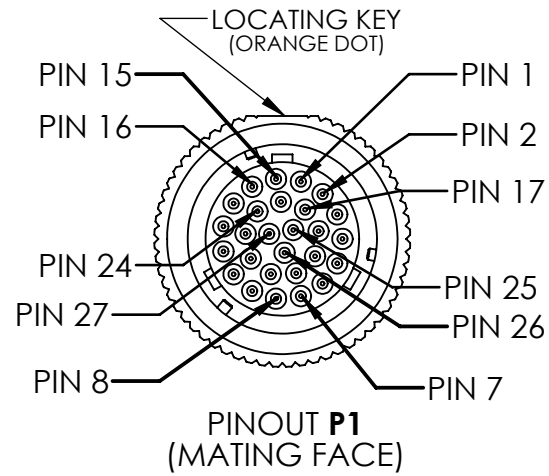

NOTES:

- 1) SOLDERING IAW IPC-J-STD-001 CLASS II AS APPLICABLE.
- 2) CABLE ASSEMBLIES TO BE TESTED 100% FOR CONTINUITY (3 OHM MAX), SHORTS, AND INSULATION RESISTANCE (150 VDC @ 100MOHM MINIMUM).
- 3) PLACE IN ZIP LOCK BAG.
- 4) IDENTIFICATION: IDENTIFY ON THE BAG THE FOLLOWING INFORMATION FOR EACH PART DELIVERED.  
**PN: SN-1197 REV X (REV MARKING PER PO)**  
**CAGE CODE: 1HJX9**  
**DATE OF MFG: MM/YY**
- 5) ALL LABELS SHALL BE HEAT SHRINK BLACK TUBING WITH WHITE FONT.
- 6) MANUFACTURE AND INSPECT IAW IPC/WHMA A-620 CLASS 2.
- 7) SECURE CABLE SHIELD TO P1 BACKSHELL USING BANDING CLAMP.

| UNLESS OTHERWISE SPECIFIED:                 | NAME   | DATE        |
|---|--|-------------|
| DIMENSIONS ARE IN: INCHES                   | DRAWN  | TC 5/11/21  |
| TOLERANCES: .XX: ± 0.03                     | CHECKED  | RJB 5/11/21 |
| .XXX: ± 0.005                               | COMMENTS:  |             |
| ANGULAR: .X°: 1°                            | <b>PROPRIETARY AND CONFIDENTIAL</b>  |             |
| .XX*: 0.5°                                  | THE INFORMATION CONTAINED IN THIS DRAWING IS THE SOLE PROPERTY OF SUPPLYNET, INC. ANY REPRODUCTION IN PART OR AS A WHOLE WITHOUT THE WRITTEN PERMISSION OF SUPPLYNET INC. IS PROHIBITED. |             |
| BREAK EDGES: .005 - .020                    | <b>CAGE CODE: 1HJX9</b>  |             |
| FILLETS: .005 - .020                        | DO NOT SCALE DRAWING   |             |
| SURFACE FINISH:                             |  |             |
| GEOMETRIC TOLERANCING PER: ASME Y14.5 -2009 |  |             |
| MATERIAL: SEE DRAWING NOTES                 |  |             |
| FINISH: SEE DRAWING NOTES                   |  |             |

|              |   |              |
|--------------|---|--------------|
| REF. NUMBER: | SN0816                                  |              |
|              |   |              |
| TITLE:       | <b>NRG TO AN/PRC-160 CABLE ASSEMBLY</b> |              |
| SIZE         | DWG. NO.                                | REV          |
| <b>B</b>     | <b>SN-1197</b>                          | <b>A</b>     |
| SCALE: NA    | WEIGHT:                                 | SHEET 1 OF 1 |