

WIRE RUN LIST (P1 TO P3)		
PCB	P1	P3
(+)24V	RED	→ RED
(-) GND	BLACK	BLACK

TABLE 1: WIRE RUN LIST		
PCB	P2	P3
(+)24V	RED	→ WHITE
(-)GND	BLACK	GREEN

*PLACE DIODE ON (+)24V OUT OF P1 & P2

*CAP AND STOW ANY UNUSED WIRES.

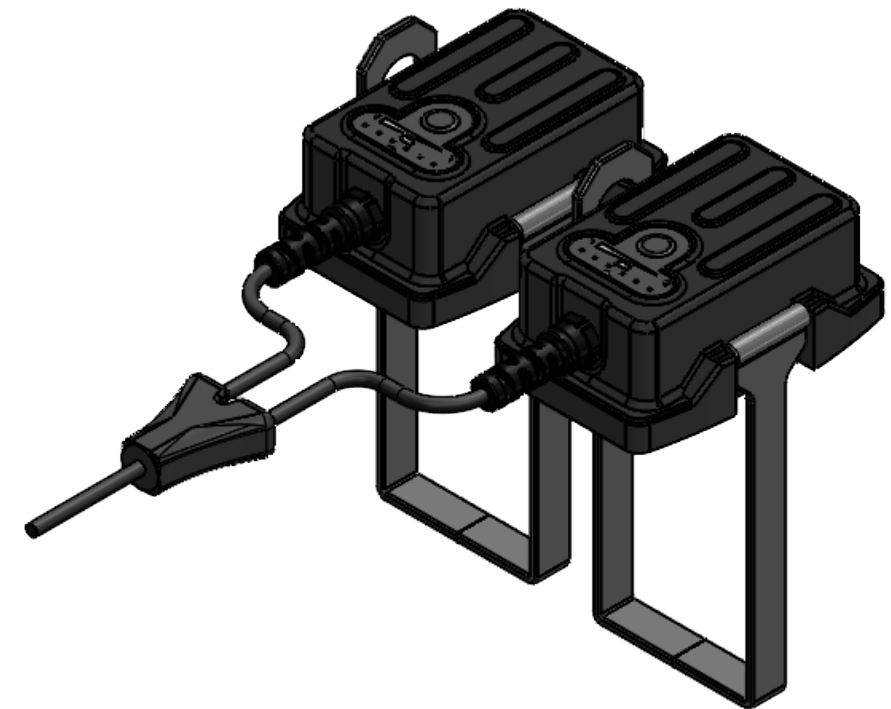
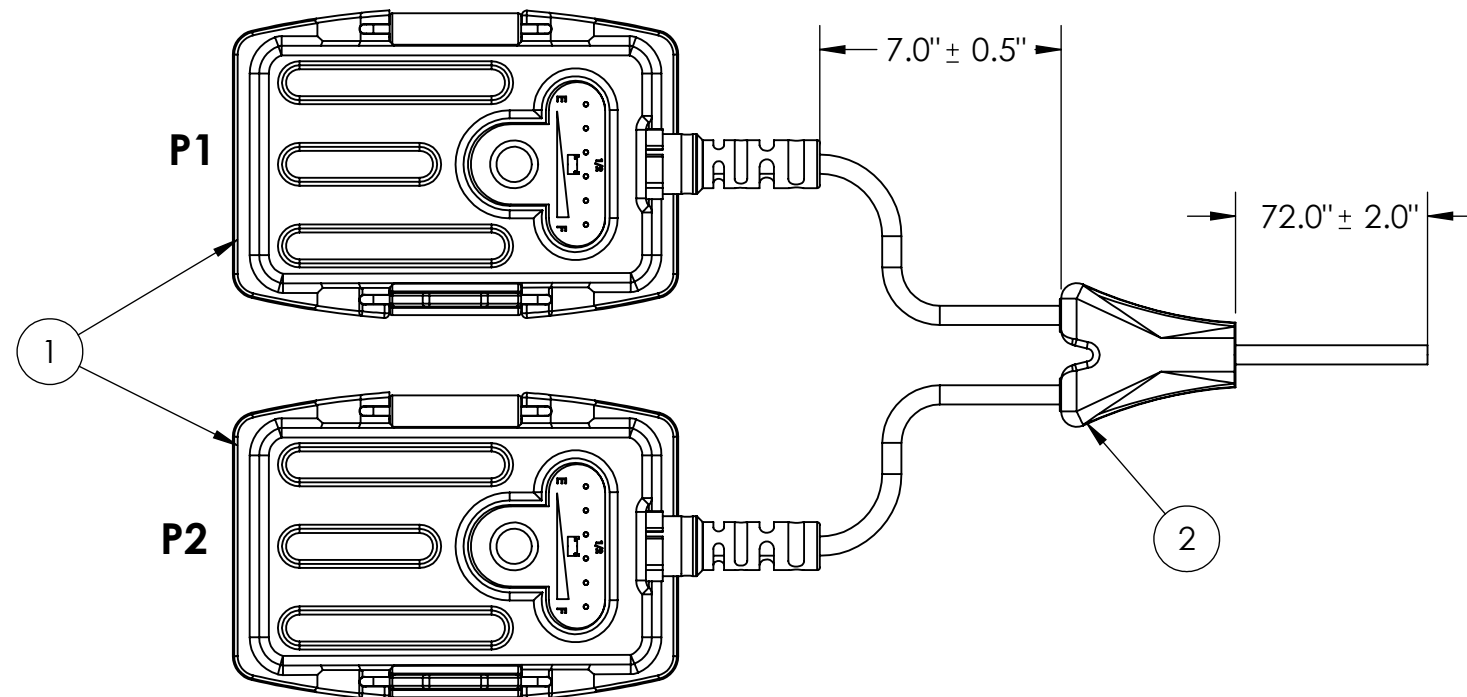

*BATTERIES NOT SHOWN

BILL OF MATERIALS				
ITEM NO.	PART NO.	QTY	NAME/DESCRIPTION	SUPPLIER CODE
1	SN-951-K	2	SN-951-K ASSEMBLY WATERTIGHT, 24V REGULATED	SN
2	WIRE-926-DB	AR	CABLE, AWG 20, 4C, WITH Y-SPLITTER OD: 0.20"	SN
3	1655-SB10150TB-ND	2	SCHOTTKY DIODE, 10A	SCS

NOTES:

- WIRE FUNCTION: SEE TABLE 1 WIRE RUN LIST. (CAP AND STOW ANY UNUSED WIRES).
- CABLE LENGTH: 72.0" ± 2.0".
- ASSEMBLY TO BE 100% TESTED FOR CONTINUITY, SHORTS, AND JACKET RESISTANCE.
- SOLDERING: IAW IPC-J-STD-001 CLASS II AS APPLICABLE.
- IDENTIFICATION: BAG AND IDENTIFY ON PACKAGING THE FOLLOWING INFORMATION FOR EACH PART DELIVERED. PART MARKING ON THE WIRE IS PROHIBITED.
PN: SN-951-KX-06 REV. X (REV. "X" AS PER PO)
CAGE CODE: 1HJX9
MFD: MM/YY
- REFERENCE SUPPLYNET FILE NUMBER SN0745.
- MANUFACTURE AND INSPECT IAW IPC/WHMA A-620 CLASS 2.

SUPPLIER CODE KEY	
CODE	MEANING
SCS	SUB-CON SOURCED & SUPPLIED
SN	SUPPLYNET SOURCED & SUPPLIED
-L	LONG LEAD TIME ITEM

UNLESS OTHERWISE SPECIFIED:
 DIMENSIONS ARE IN: INCHES
 TOLERANCES: .XX: ± 0.03
 .XXX: ± 0.005
 ANGULAR: .X°: 1°
 .XX°: 0.5°
 BREAK EDGES: .005 - .020
 FILLETS: .005 - .020
 SURFACE FINISH:
 GEOMETRIC TOLERANCING
 PER: ASME Y14.5 -2009
 MATERIAL: SEE DRAWING NOTES
 FINISH: SEE DRAWING NOTES
 DO NOT SCALE DRAWING

NAME	DATE
DRAWN: MOB	5/22/2020
CHECKED: RB	5/22/2020
COMMENTS:	

REF. NUMBER: SN0745



TITLE: DUAL WATERTIGHT BB2590
24V REGULATED
WITH FUEL GAUGE

SIZE: **B** DWG. NO.: SN-951-KX-06 REV: **B**

SCALE: NA WEIGHT: SHEET 1 OF 1

CAGE CODE: 1HJX9