

TABLE 1: WIRING		
P1	WIRE COLORS	FORK TERMINALS
1	BLACK	P2
3	RED (FUSE)	P3

REVISIONS			
REV.	DESCRIPTION	DATE	ENG
A	INITIAL REV.	3/20/20	TC
B	CHANGED NOTE #7	9/9/21	MOB

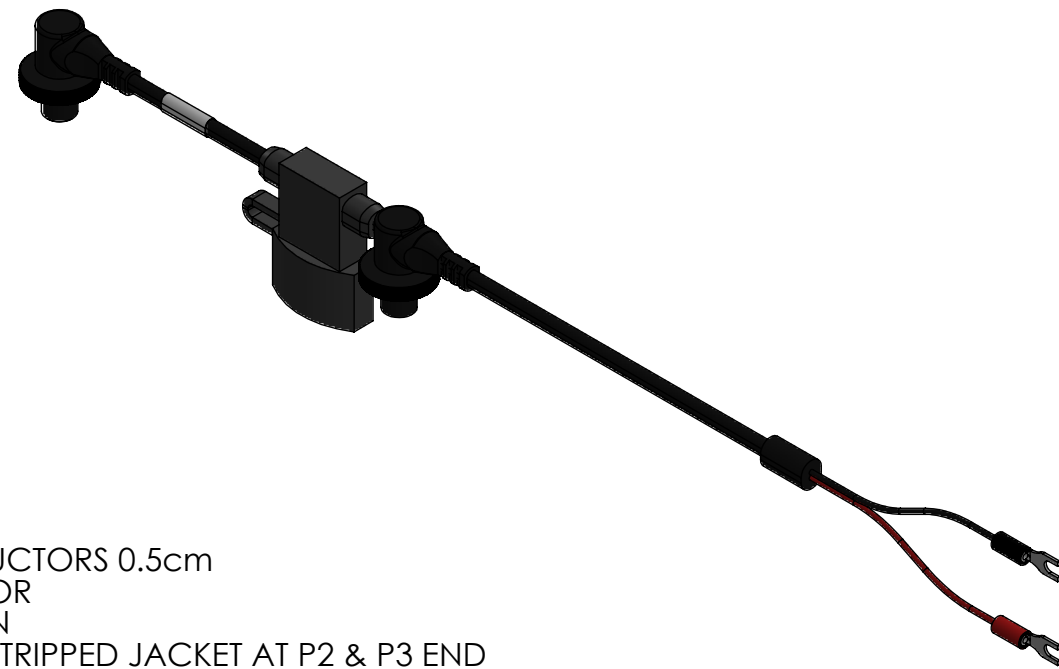
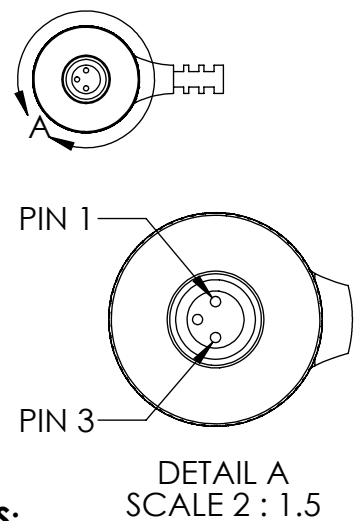
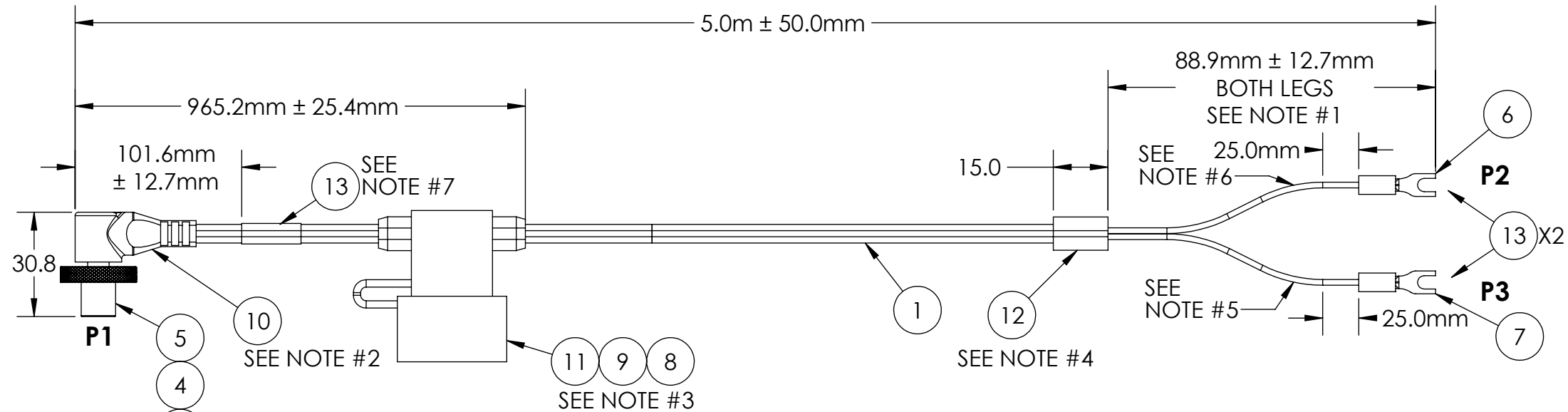

TABLE 2: BILL OF MATERIALS			
ITEM NO.	PART NO	QTY	NAME/DESCRIPTION
1	0429-2-18	5.0M	2 COND., 20AWG, FLAT, BLK PU JKT
2	0429-1-01	1	INSULATOR
3	0429-1-PIN	2	PIN
4	0429-1-NUT	1	SPINNER M8 X 1.0
5	0429-1-OR	1	O-RING
6	0429-1-BF	1	18 GAGE BLK FORK TERMINAL, TEFLON
7	0429-1-RF	1	18 GAGE RED FORK TERMINAL, TEFLON
8	0429-1-FP	2	FUSE PIN
9	0429-2-32	1	32V, 2 AMP FUSE
10	0429-OM-COAX90	1	BLACK OVER-MOLD
11	0429-OM-FUSE	1	BLACK OVER-MOLD
12	0429-OM-SML	1	BLACK OVER-MOLD
13	0429-WA-1	3	1 INCH WRAP AROUND LABEL

**NOTES:**

- STRIP JACKET 9.0cm AND STRIP CONDUCTORS 0.5cm
- BLACK OVER-MOLD ON P1 CONNECTOR
- BLACK OVER-MOLD AT FUSE LOCATION
- BLACK OVER-MOLD CENTERED OVER STRIPPED JACKET AT P2 & P3 END
- WHITE HEAT SHRINK LABEL 20mm LENGTH - BLACK TEXT  
LINE #1: + + + + +
- WHITE HEAT SHRINK LABEL 20mm LENGTH - BLACK TEXT  
LINE #1: - - - - -
- WHITE HEAT SHRINK LABEL - BLACK TEXT  
LINE #1: SN-987-5019-002 REV. X (REV. "X" AS PER PO)  
LINE #2: CAGE CODE: 1HJX9  
LINE #3: MM/YY
- BUILD TO IPC/WHMA-A-620 STANDARDS OR MOST CURRENT VERSION

UNLESS OTHERWISE SPECIFIED:	NAME	DATE
DIMENSIONS ARE IN: INCHES	DRAWN	TC 3/30/20
TOLERANCES: .XX: ± 0.03	CHECKED	RB 3/30/20
.XXX: ± 0.005	COMMENTS:	
ANGULAR: .X°: 1°		
.XX°: 0.5°		
BREAK EDGES: .005 - .020		
FILLET: .005 - .020		
SURFACE FINISH:		
GEOMETRIC TOLERANCING PER: ASME Y14.5-2009	<b>PROPRIETARY AND CONFIDENTIAL</b>	
MATERIAL: SEE DRAWING NOTES	THE INFORMATION CONTAINED IN THIS DRAWING IS THE SOLE PROPERTY OF SUPPLYNET, INC. ANY REPRODUCTION IN PART OR AS A WHOLE WITHOUT THE WRITTEN PERMISSION OF SUPPLYNET INC. IS PROHIBITED.	
FINISH: SEE DRAWING NOTES		
DO NOT SCALE DRAWING	<b>CAGE CODE: 1HJX9</b>	

REF. NUMBER: SN0629	706 EXECUTIVE BLVD. SUITE B VALLEY COTTAGE, NY 10989	
TITLE: <b>DAGR RIGHT ANGLE 90° WEST POWER CABLE W/FUSE</b>		
SIZE <b>B</b>	DWG. NO. <b>SN-987-5019-002</b>	REV <b>B</b>
SCALE: NA	WEIGHT:	SHEET 1 OF 1