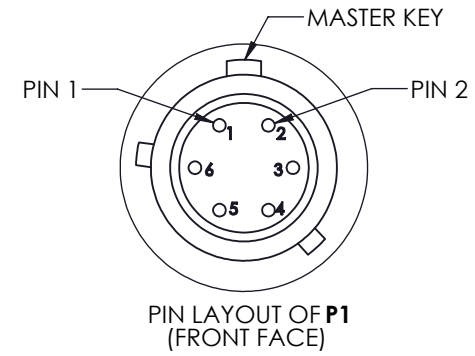
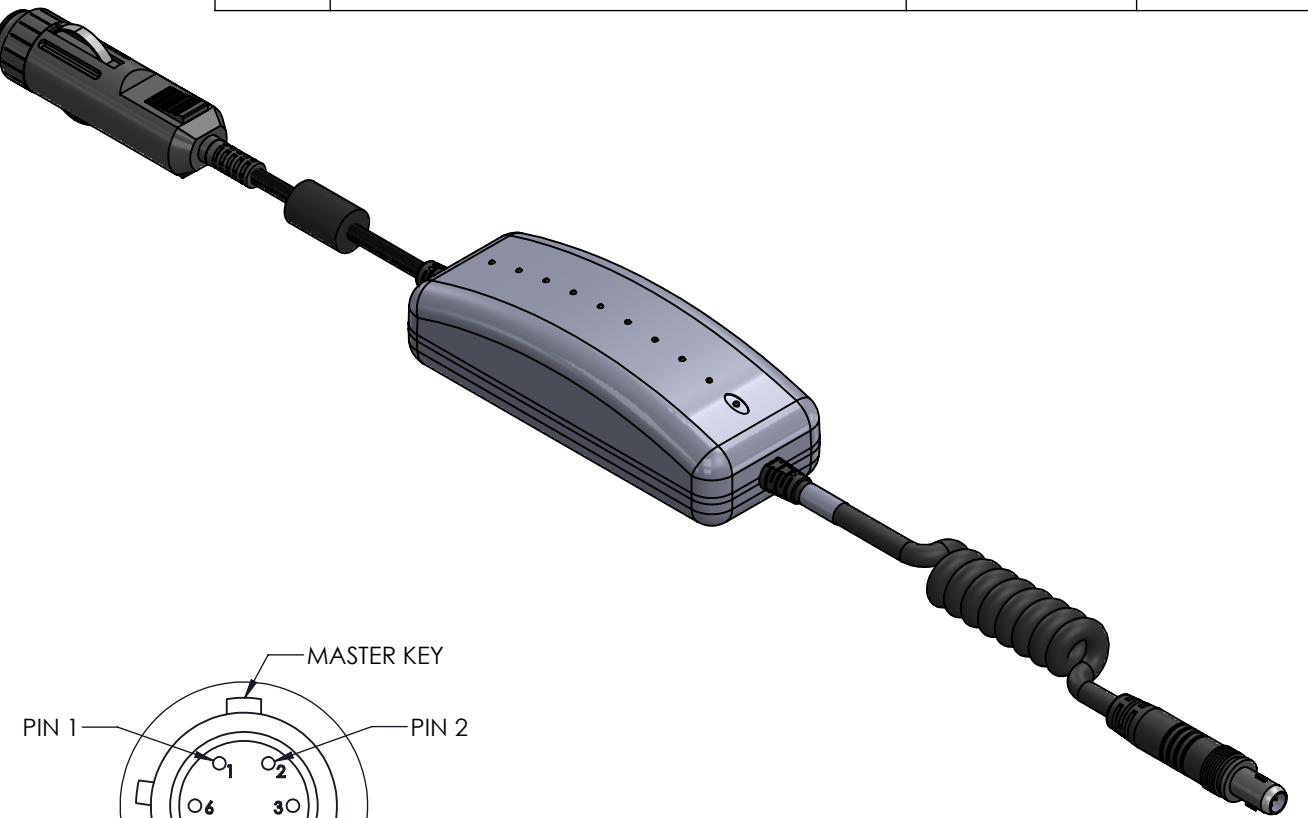
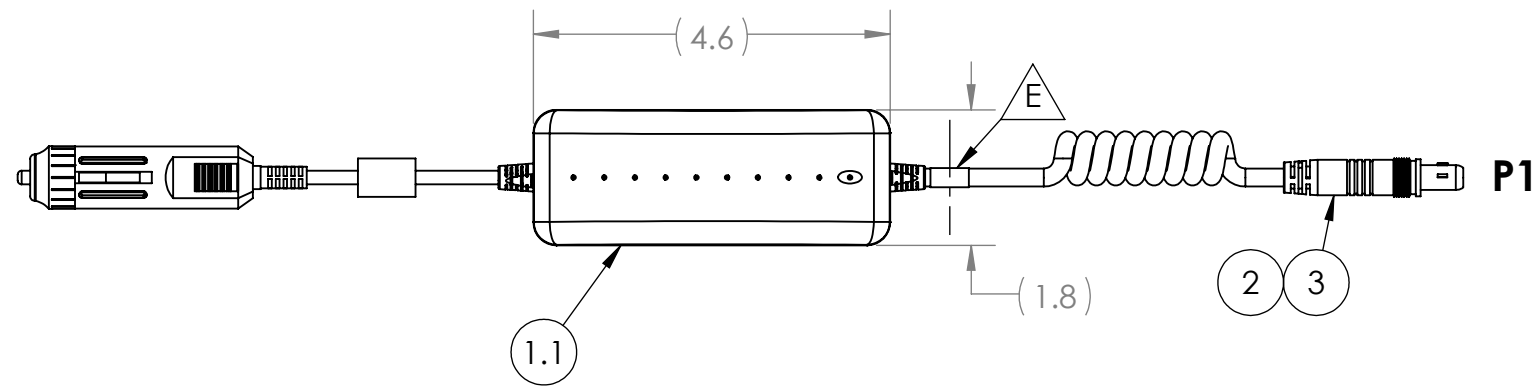
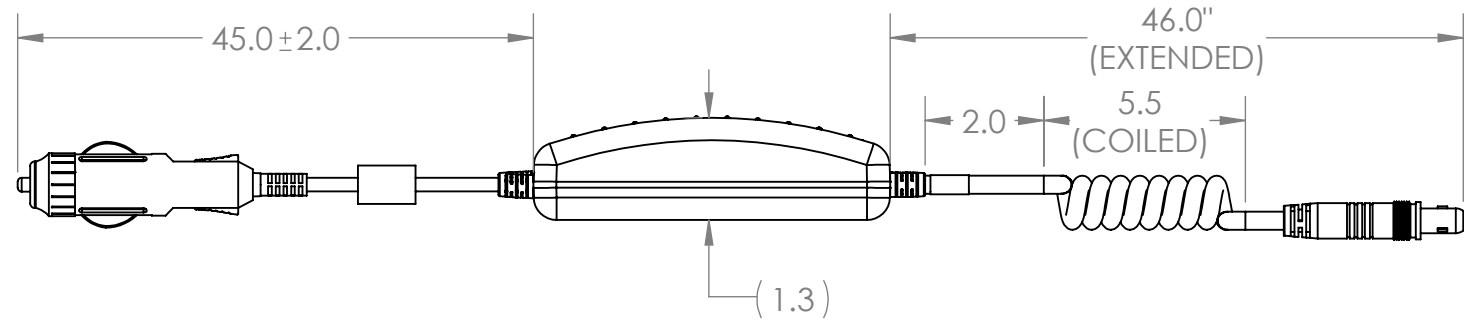

TABLE 1: WIRE RUN		
DC POWER ADAPTER	WIRE COLOR	P1
15VDC	BLACK	1
GND	WHITE	2

REVISIONS			
REV.	DESCRIPTION	DATE	ENG
A	INITIAL RELEASE	9/20/23	CWA
B	MODEL & NOTES UPDATED	01/08.23	CWA

INPUT: 11-28VDC
OUTPUT: 15VDC, 4.0A MAX



BILL OF MATERIALS				
ITEM NO.	PART NO.	QTY	NAME/DESCRIPTION	SUPPLIER CODE
1	SN-00-1004-C	1	12VDC POWER SUPPLY ADAPTER NETT WARRIOR FEMALE	SN
1.1	VDN60-150A	1	DC-DC POWER SUPPLY, INPUT: 11-28VDC OUTPUT: 15VDC, 4.0A	SCS
2	807-309-06ZNU6-6PY	1	NETT WARRIOR MALE, 6 POS., PIN CONTACTS	SN
3	BE-04	1	BANDING CLAMP	SN

- NOTES:
- WIRING SHALL BE DONE IN ACCORDANCE WITH TABLE 1 WIRE RUN LIST.
 - MARKING REQUIREMENTS:
 - LABELS SHALL BE MARKED IN ACCORDANCE WITH MIL-STD-130 AS APPLICABLE.
 - LABELS SHALL BE WHITE WITH BLACK TEXT.
 - LABELS SHALL BE PLACED WHERE SHOWN IN DRAWING.
 - ADHESIVE WRAP AROUND LABEL MAY BE USED.
 - LABEL SHALL BE MARKED WITH THE BELOW INFORMATION ONLY. (REV MARKING PER PO)
PN: SN-00-1004-NW REV. X
CAGE: 1HJX9
MFD: MM/YY
 - PACKAGING:
 - EACH COMPLETED ASSEMBLY SHALL BE PLACED IN A ZIP-POLY BAG AND MARKED PER SN-STD-LBL
 - ZIP POLY BAG: 6.5"X10", 4 MIL
 - SOLDERING: IAW IPC-J-STD-001 CLASS 2 AS APPLICABLE
 - ASSEMBLY TO BE 100% TESTED FOR SHORTS, CONTINUITY, AND OPERATION.
 - MANUFACTURE AND INSPECT IAW IPC/WHMA A-620 CLASS 2.

UNLESS OTHERWISE SPECIFIED:		NAME	DATE	REF. NUMBER: 1013										
DIMENSIONS ARE IN: INCHES TOLERANCES: .XX: ± 0.03 .XXX: ± 0.005 ANGULAR: .X°: 1° .XX°: 0.5° BREAK EDGES: .005 - .020 FILLETS: .005 - .020 SURFACE FINISH:		DRAWN	MOB 5/22/2023											
GEOMETRIC TOLERANCING PER: ASME Y14.5 -2009		CHECKED	RB 5/22/2023	 DESIGN ENGINEERING MANUFACTURING										
MATERIAL: SEE DRAWING NOTES FINISH: SEE DRAWING NOTES		COMMENTS:												
DO NOT SCALE DRAWING		PROPRIETARY AND CONFIDENTIAL THE INFORMATION CONTAINED IN THIS DRAWING IS THE SOLE PROPERTY OF SUPPLYNET, INC. ANY REPRODUCTION IN PART OR AS A WHOLE WITHOUT THE WRITTEN PERMISSION OF SUPPLYNET INC. IS PROHIBITED.		TITLE: 12VDC POWER ADAPTER TO NETT WARRIOR MALE, OUTPUT: 15VDC, 60W										
<table border="1"> <thead> <tr> <th colspan="2">SUPPLIER CODE KEY</th> </tr> <tr> <th>CODE</th> <th>MEANING</th> </tr> </thead> <tbody> <tr> <td>SCS</td> <td>SUB-CONTRACTOR SOURCED & SUPPLIED</td> </tr> <tr> <td>SN</td> <td>SUPPLYNET SOURCED & SUPPLIED</td> </tr> <tr> <td>-L</td> <td>LONG LEAD TIME ITEM</td> </tr> </tbody> </table>		SUPPLIER CODE KEY			CODE	MEANING	SCS	SUB-CONTRACTOR SOURCED & SUPPLIED	SN	SUPPLYNET SOURCED & SUPPLIED	-L	LONG LEAD TIME ITEM	CAGE CODE: 1HJX9	
SUPPLIER CODE KEY														
CODE	MEANING													
SCS	SUB-CONTRACTOR SOURCED & SUPPLIED													
SN	SUPPLYNET SOURCED & SUPPLIED													
-L	LONG LEAD TIME ITEM													
		DWG. NO. SN-00-1004-NW		REV B										
		SCALE: NA	WEIGHT:	SHEET 1 OF 1										