

TABLE 1: WIRING		
P1	WIRE COLORS	FORK TERMINALS
1	BLACK	P2
3	RED (FUSE)	P3

REVISIONS			
REV.	DESCRIPTION	DATE	APPROVED
A	INITIAL REV.	09/29/20	TC
B	CHANGED NOTE #7 AND TITLE	09/09/21	MOB
	REDRAWN WITHOUT CHANGE: UPDATED DRAWING	11/17/23	CWA
C	CORRECTED OVERALL LENGTH	2/5/2024	MOB

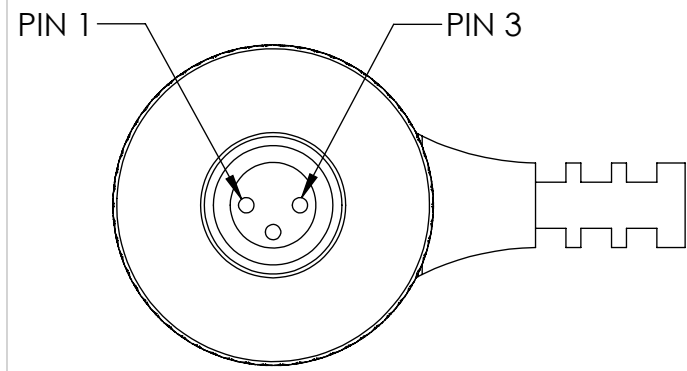
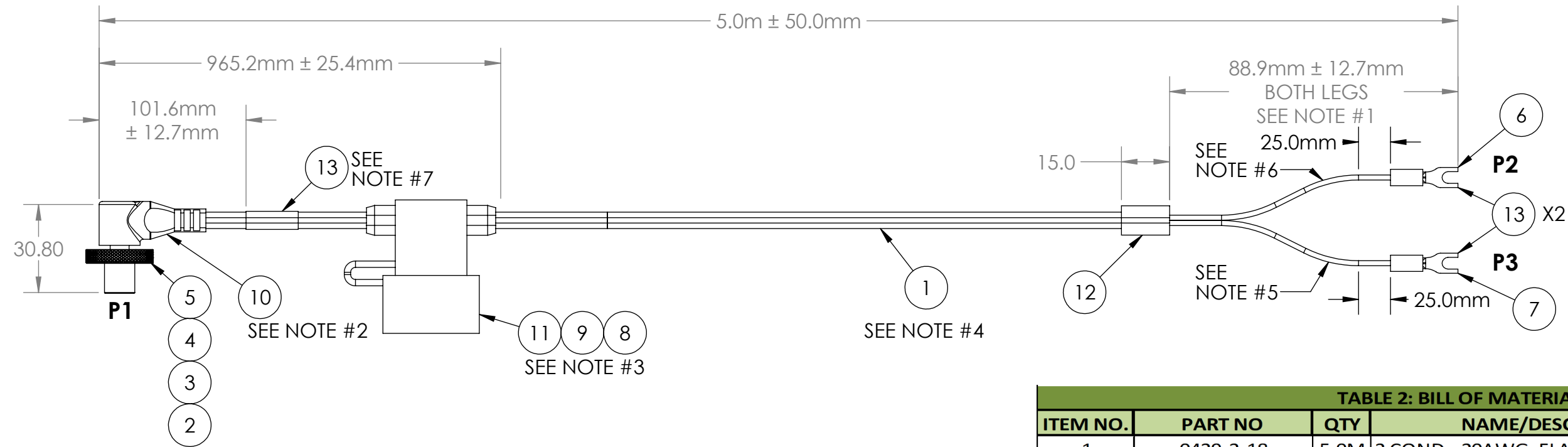

TABLE 2: BILL OF MATERIALS			
ITEM NO.	PART NO	QTY	NAME/DESCRIPTION
1	0429-2-18	5.0M	2 COND., 20AWG, FLAT, BLK PU JKT
2	0429-1-01	1	INSULATOR
3	0429-1-PIN	2	PIN
4	0429-1-NUT	1	SPINNER M8 X 1.0
5	0429-1-OR	1	O-RING
6	0429-1-BF	1	18 GAGE BLK FORK TERMINAL, TEFLON
7	0429-1-RF	1	18 GAGE RED FORK TERMINAL, TEFLON
8	0429-1-FP	2	FUSE PIN
9	0429-2-32	1	32V, 2 AMP FUSE
10	0429-OM-COAX90	1	BLACK OVER-MOLD
11	0429-OM-FUSE	1	BLACK OVER-MOLD
12	0429-OM-SML	1	BLACK OVER-MOLD
13	0429-WA-1	3	1 INCH WRAP AROUND LABEL

NOTES:

- STRIP JACKET 9.0cm AND STRIP CONDUCTORS 0.5cm
- BLACK OVER-MOLD ON P1 CONNECTOR
- BLACK OVER-MOLD AT FUSE LOCATION
- BLACK OVER-MOLD CENTERED OVER STRIPPED JACKET AT P2 & P3 END
- WHITE HEAT SHRINK LABEL 20mm LENGTH - BLACK TEXT
LINE #1: + + + + +
- WHITE HEAT SHRINK LABEL 20mm LENGTH - BLACK TEXT
LINE #1: - - - - -
- WHITE HEAT SHRINK LABEL - BLACK TEXT
LINE #1: SN-987-5019-003 REV. X (REV. "X" AS PER PO)
LINE #2: CAGE CODE: 1HJX9
LINE #3: MM/YY
- BUILD TO IPC/WHMA-A-620 STANDARDS OR MOST CURRENT VERSION

UNLESS OTHERWISE SPECIFIED:
 DIMENSIONS ARE IN: INCHES
 TOLERANCES: .XX: ± 0.03
 .XXX: ± 0.005
 ANGULAR: .X°: 1°
 .XX°: 0.5°
 BREAK EDGES: .005 - .020
 FILLETS: .005 - .020
 SURFACE FINISH:
 GEOMETRIC TOLERANCING
 PER: ASME Y14.5 -2009
 MATERIAL: SEE DRAWING NOTES
 FINISH: SEE DRAWING NOTES
 DO NOT SCALE DRAWING

NAME	DATE
DRAWN TC	9/29/20
CHECKED RB	9/29/20
COMMENTS:	

PROPRIETARY AND CONFIDENTIAL
 THE INFORMATION CONTAINED IN THIS DRAWING IS THE SOLE PROPERTY OF SUPPLYNET, INC. ANY REPRODUCTION IN PART OR AS A WHOLE WITHOUT THE WRITTEN PERMISSION OF SUPPLYNET INC. IS PROHIBITED.

REF. NUMBER: SN0629

SupplyNet DESIGN ENGINEERING MANUFACTURING

TITLE: **DAGR RIGHT ANGLE 90° SOUTH POWER CABLE W/FUSE**

SIZE B	DWG. NO. SN-987-5019-003	REV C
SCALE: NA	WEIGHT:	SHEET 1 OF 1