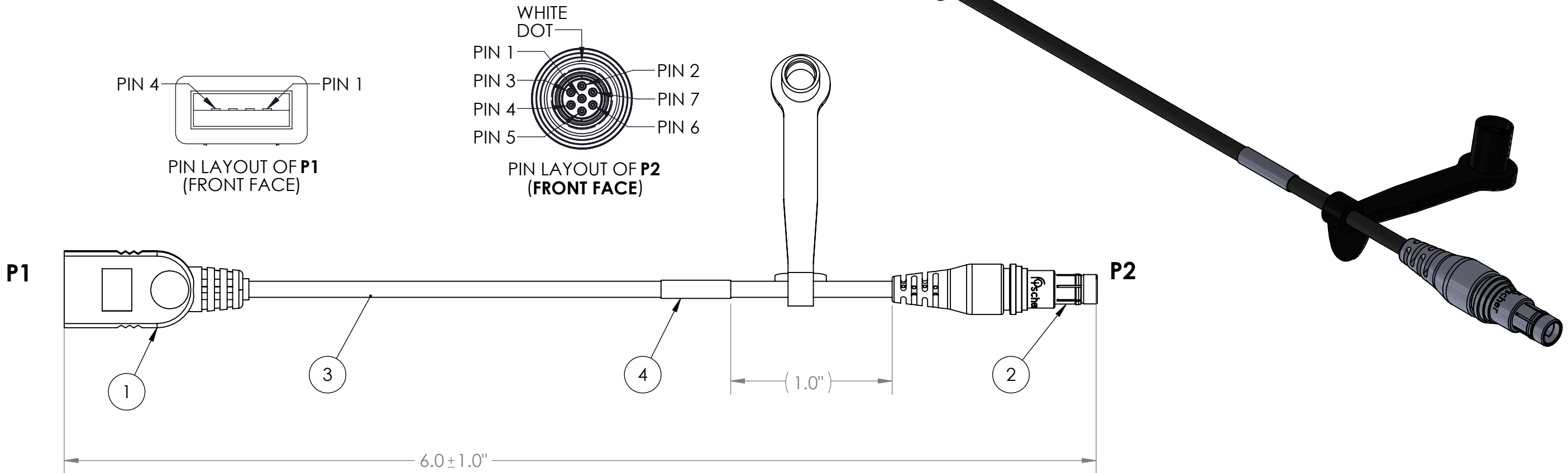

TABLE 1: CONNECTIONS		
P1 (USB A (F))	WIRE COLOR	P2 (FISCHER)
1	WHITE	7
2	RED	5
3	GREEN	1
4, SHEILD	BLACK	3,4,SHEILD

TWISTED PAIR

REVISIONS			
REV.	DESCRIPTION	DATE	ENG
A	INITIAL REV.	11/10/2020	TC
B	CHANGED ITEM #3 PN	6/23/2022	MOB
C	ITEM #1 UPDATED	12/19/2023	CWA



**NOTES:**

- JACKET: BLACK MATTE FINISH.
- SOLDERING IAW IPC-J-STD-001 CLASS II AS APPLICABLE.
- CABLE ASSEMBLIES TO BE 100% TESTED FOR CONTINUITY, SHORTS AND INSULATION RESISTANCE (250V @100MOHM MINIMUM)
- IDENTIFICATION: BAG AND IDENTIFY ON PACKAGING THE FOLLOWING INFORMATION FOR EACH PART DELIVERED. UOS PART MARKING ON THE WIRE IS PROHIBITED:

**PN: SN-12043-0870-A06 REV X** (REV. X PER PO)  
**CAGE CODE: 1HJX9**  
**DATE OF MFGR: MM/YY** (MM= MONTH MANUFACTURED, YY= LAST TWO DIGITS OF YEAR)

- MANUFACTURE AND INSPECT IAW IPC/WHMA A- 620 CLASS 2.
- CAP AND STOWE UNUSED WIRES.
- ALL OVERMOLDS ARE TO BE BLACK. ITEM #2 TO BE OVERMOLDED USING OM-26.
- HEATSHRINK LABEL WILL BE PROVIDED BY WINCHESTER INTERCONNECT (ITEM #5). PLACE LABEL ON WIRE PRIOR TO ATTACHING CONNECTORS. SLIDE LABEL TO APPROPRIATE LOCATION AND APPLY HEAT UNTIL SECURED. LABEL FORMAT:

**PN: SN-12043-0870-A06 REV X** (REV. X PER PO)  
**CAGE CODE: 1HJX9**  
**DATE OF MFGR: MM/YY** (MM= MONTH MANUFACTURED, YY= LAST TWO DIGITS OF YEAR)

BILL OF MATERIALS				
ITEM NO.	PART NUMBER	QTY	NAME/DESCRIPTION	SUPPLIER CODE
1	RR-AFX2-144G	0.5	USB 2 EXTENSION CABLE - FEMALE TO FEMALE - 144 IN.	SN
2	SS102Z056-140	1	7 PIN FISCHER CONNECTOR	SN
3	53120	1	7 CONDUCTOR OVERALL SHIELDED AND JACKETED CABLE	SCS
4	LBL-077	1	HEAT SHRINK LABEL, BLACK WITH WHITE LETTERING, SEE NOTE #8 (PROVIDED BY WINCHESTER INTERCONNECT)	SCS
5	809-083-06G6-SK	1	DUST CAP	SN

UNLESS OTHERWISE SPECIFIED:		NAME	DATE
DIMENSIONS ARE IN: INCHES		DRAWN	TC 11/10/20
TOLERANCES: .XX: ± 0.03		CHECKED	RJB 11/10/20
.XXX: ± 0.005		COMMENTS:	
ANGULAR: .X°: 1°		<p><b>PROPRIETARY AND CONFIDENTIAL</b></p> <p>THE INFORMATION CONTAINED IN THIS DRAWING IS THE SOLE PROPERTY OF SUPPLYNET, INC. ANY REPRODUCTION IN PART OR AS A WHOLE WITHOUT THE WRITTEN PERMISSION OF SUPPLYNET INC. IS PROHIBITED.</p>	
.XX*: 0.5°		<p><b>CAGE CODE: 1HJX9</b></p>	
BREAK EDGES: .005 - .020		<p>SCALE: NA WEIGHT: SHEET 1 OF 1</p>	
FILLET: .005 - .020			
SURFACE FINISH:			
GEOMETRIC TOLERANCING PER: ASME Y14.5 -2009			
MATERIAL: SEE DRAWING NOTES			
FINISH: SEE DRAWING NOTES			
DO NOT SCALE DRAWING			

SUPPLIER CODE KEY	
CODE	MEANING
SCS	SUB-CONTRACTOR SOURCED & SUPPLIED
SN	SUPPLYNET SOURCED & SUPPLIED
-L	LONG LEAD TIME ITEM

REF. NUMBER: SN0761

**SupplyNet** DESIGN ENGINEERING MANUFACTURING

TITLE: **Manpack J4 to Female USB Adapter (Cross Ref: 12043-0870-A06)**

SIZE **B** DWG. NO. **SN-12043-0870-A06** REV **C**