

TABLE 1: WIRE RUN	
P1	WIRE COLOR
5	RED
1	BLACK
2, 4	JUMPER WIRE

TABLE 2: WIRE LENGTH TABLE		
"-XX" FROM P/N	"XX" DIMENSION (FT.)	TOLERANCE (INCHES)
01	1	±1
02	2	±1
03	3	±1.5
04	4	±1.5
05	5	±2.0
06	6	±2.5
10	10	±3.0
12	12	±4.0
15	15	±4.0

FILL WITH POTTING MATERIAL PRIOR TO ASSEMBLING

SECURED USING CYANOACRYLATE ADHESIVE

APPLY CYANACRYLATE TO POSTS BEFORE ATTACHING BACKSHELL

*VELCRO STRAP NOT SHOWN

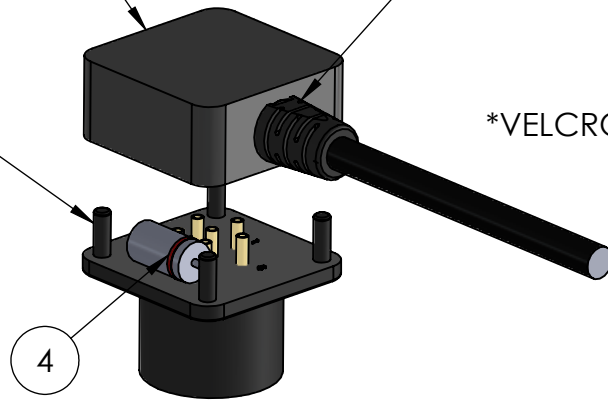

REVISIONS			
REV.	DESCRIPTION	DATE	ENG
B	UPDATED DWG FORMAT, UPDATED TO M8 THREADED SR	6/21/2023	MOB
C	TABLE 2: WIRE LENGTH TABLE ADDED	3/26/2024	CWA
D	ISO VIEW ADDED	3/26/2024	CWA

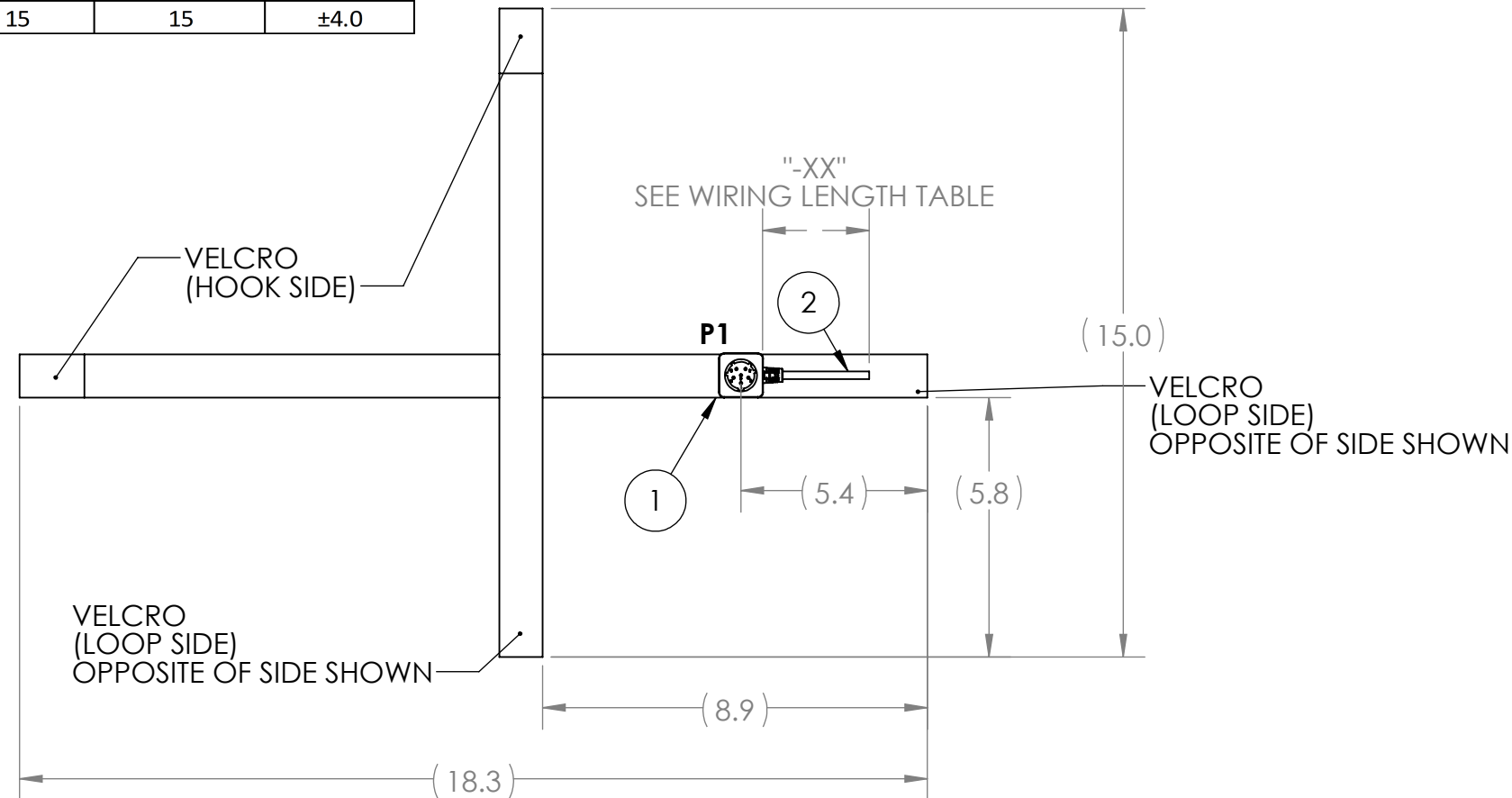
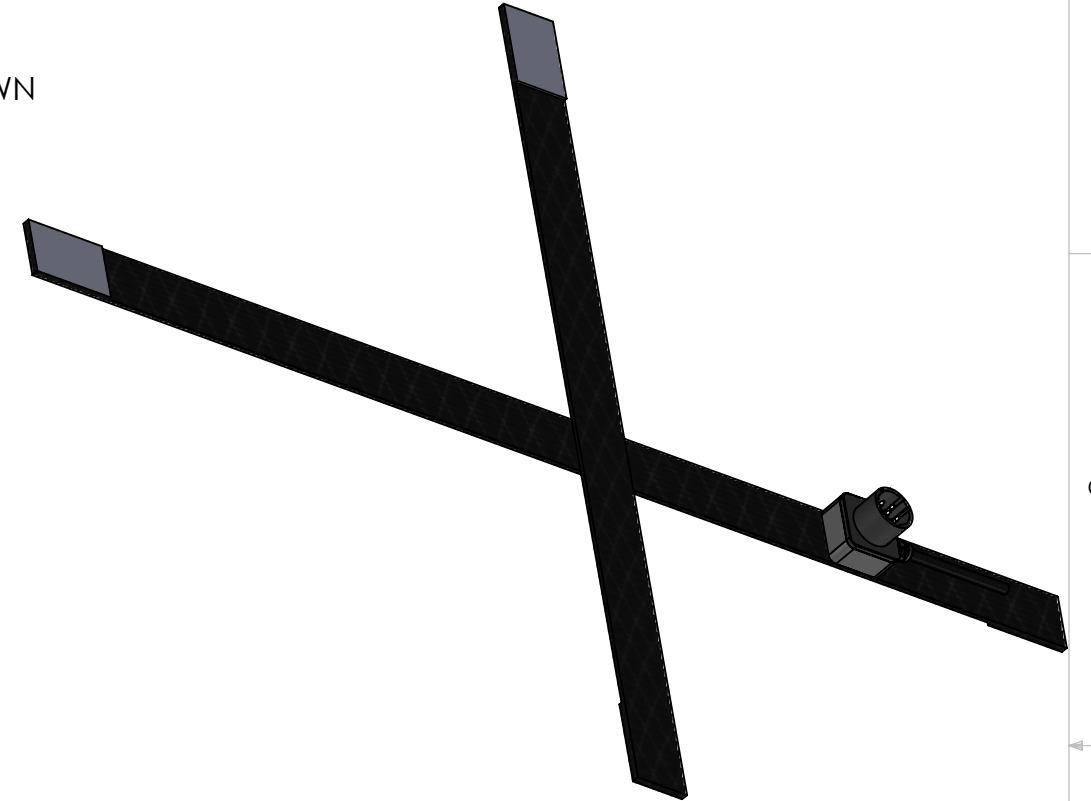

BILL OF MATERIALS			
ITEM NO.	PART NO.	QTY	NAME/DESCRIPTION
1	CONN-BA5590-MTV	1	BA-5590 CONNECTOR WITH VELCRO STRAP, M8 X 1.25 THREADED BACKSHELL.
2	202C-U07A	-XX	2C, AWG 20, PU JACKET, .181 IN. DIA.
3	SR:0024	1	M8 X 1.25 THREADED SR
4	SBM1060LSS_AY_00001 OR EQUIV.	2	60V, 10A, DIODE

- NOTES:
- WIRING SHALL BE DONE IN ACCORDANCE WITH TABLE 1 WIRE RUN LIST.
 - MARKING REQUIREMENTS:
 - EACH COMPLETED ASSEMBLY SHALL BE PLACED IN A ZIP-POLY BAG.
 - ZIP-POLY BAG SHALL BE MARKED WITH SUPPLYNET LOGO & PRODUCT QR CODE PER SN-STD-LBL.
 - SOLDERING: IAW IPC-J-STD-001 CLASS 2 AS APPLICABLE
 - ASSEMBLY TO BE 100% TESTED FOR SHORTS, CONTINUITY, AND JACKET RESISTANCE (250V @ 100MOHM MIN.)
 - MANUFACTURE AND INSPECT IAW IPC/WHMA A-620 CLASS 2.

UNLESS OTHERWISE SPECIFIED:		NAME	DATE	REF. NUMBER: SNO617
DIMENSIONS ARE IN: INCHES		DRAWN	MOB 4/3/2023	
TOLERANCES: .XX: ± 0.03		CHECKED	RB 4/3/2023	 BA-5590 24VDC CABLE WITH VELCRO STRAP
ANGULAR: .X°: 1°		COMMENTS:		
BREAK EDGES: .005 - .020		<p>PROPRIETARY AND CONFIDENTIAL</p> <p>THE INFORMATION CONTAINED IN THIS DRAWING IS THE SOLE PROPERTY OF SUPPLYNET, INC. ANY REPRODUCTION IN PART OR AS A WHOLE WITHOUT THE WRITTEN PERMISSION OF SUPPLYNET INC. IS PROHIBITED.</p>		
FILLET: .005 - .020		SIZE	DWG. NO.	REV
SURFACE FINISH:		B	191004F-VS-XX	D
GEOMETRIC TOLERANCING PER: ASME Y14.5 -2009		CAGE CODE: 1HJX9		SCALE: NA WEIGHT: SHEET 1 OF 1
MATERIAL: SEE DRAWING NOTES				
FINISH: SEE DRAWING NOTES				
DO NOT SCALE DRAWING				