

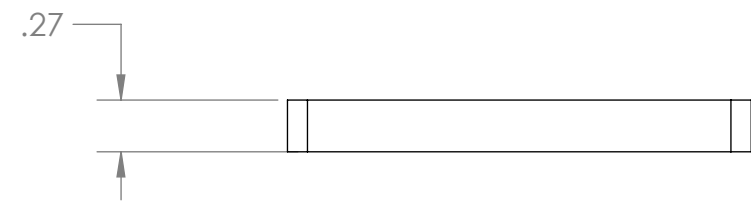

REV	DATE	DESCRIPTION OF CHANGE	ENG
C	7/20/2020	ADDED MATERIAL INFORMATION	TC

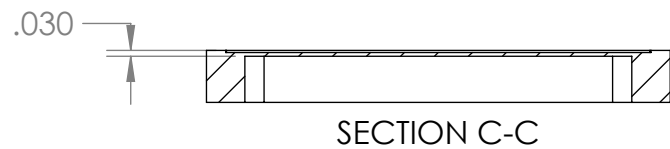
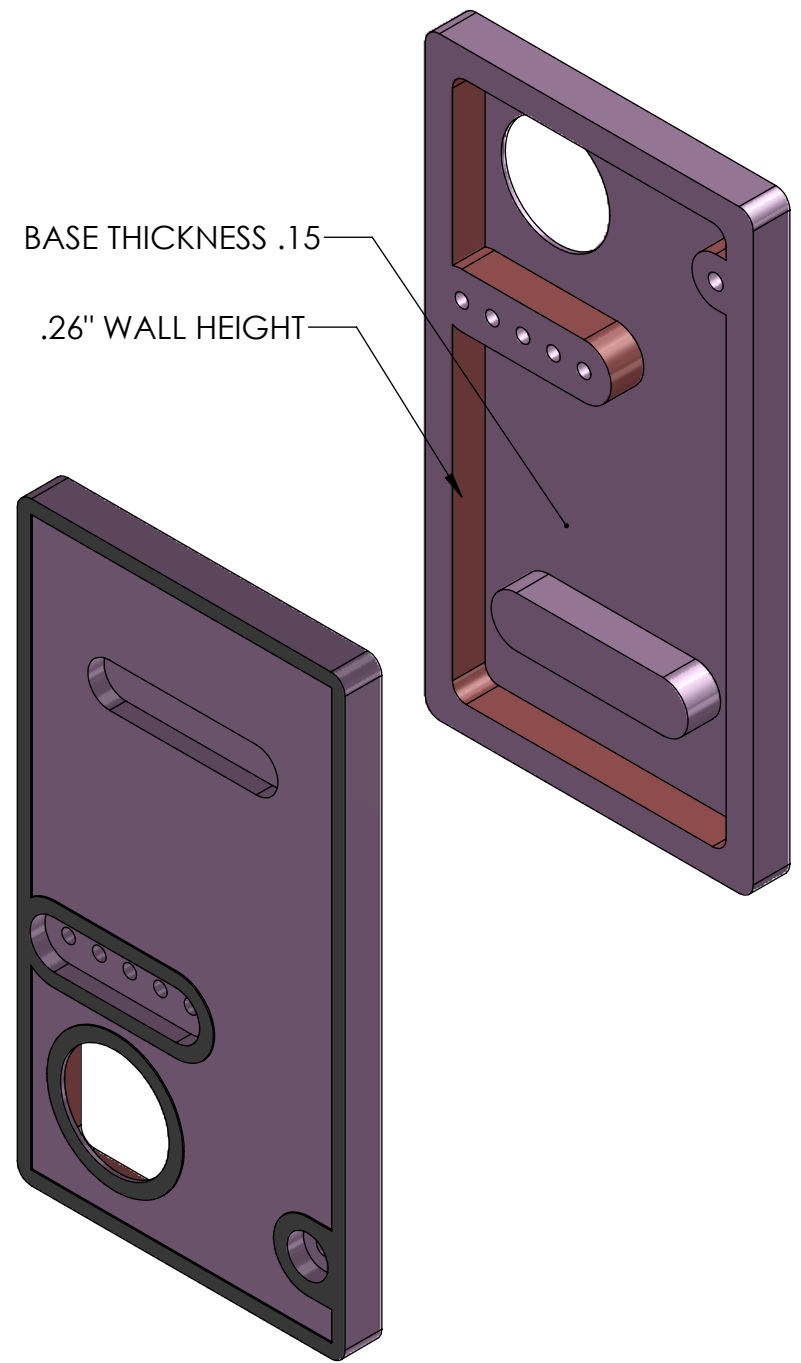
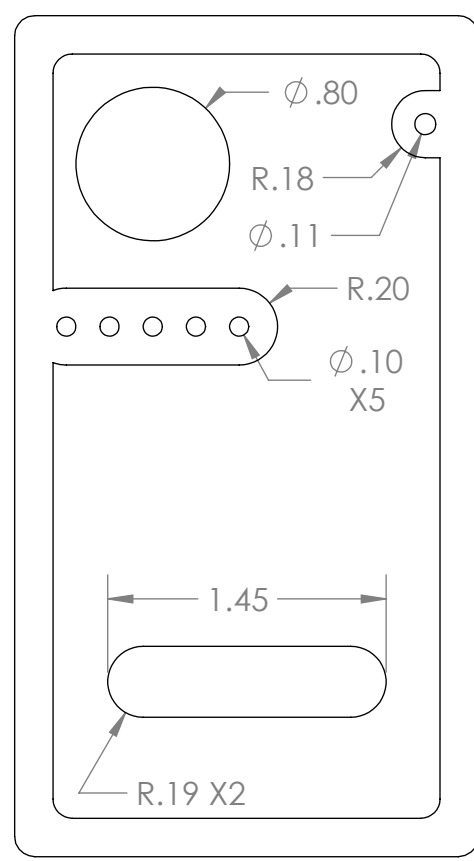
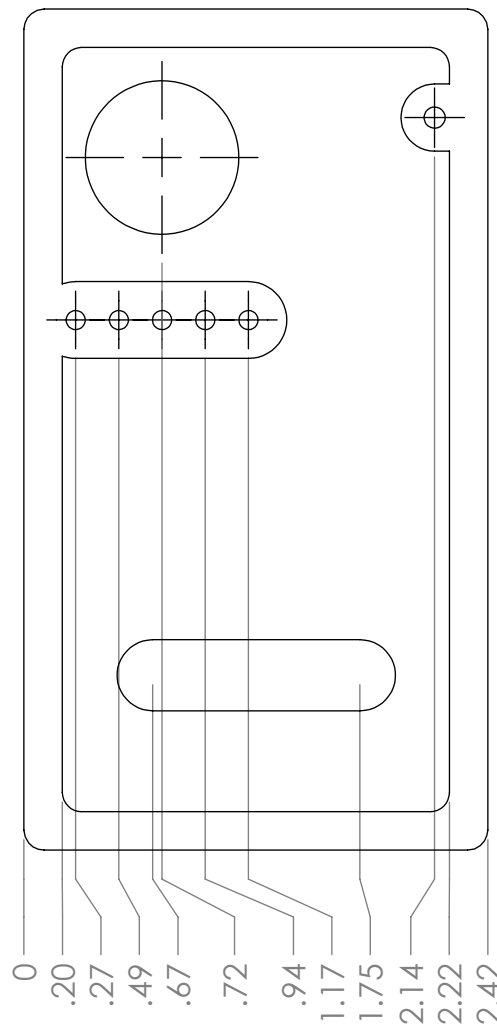
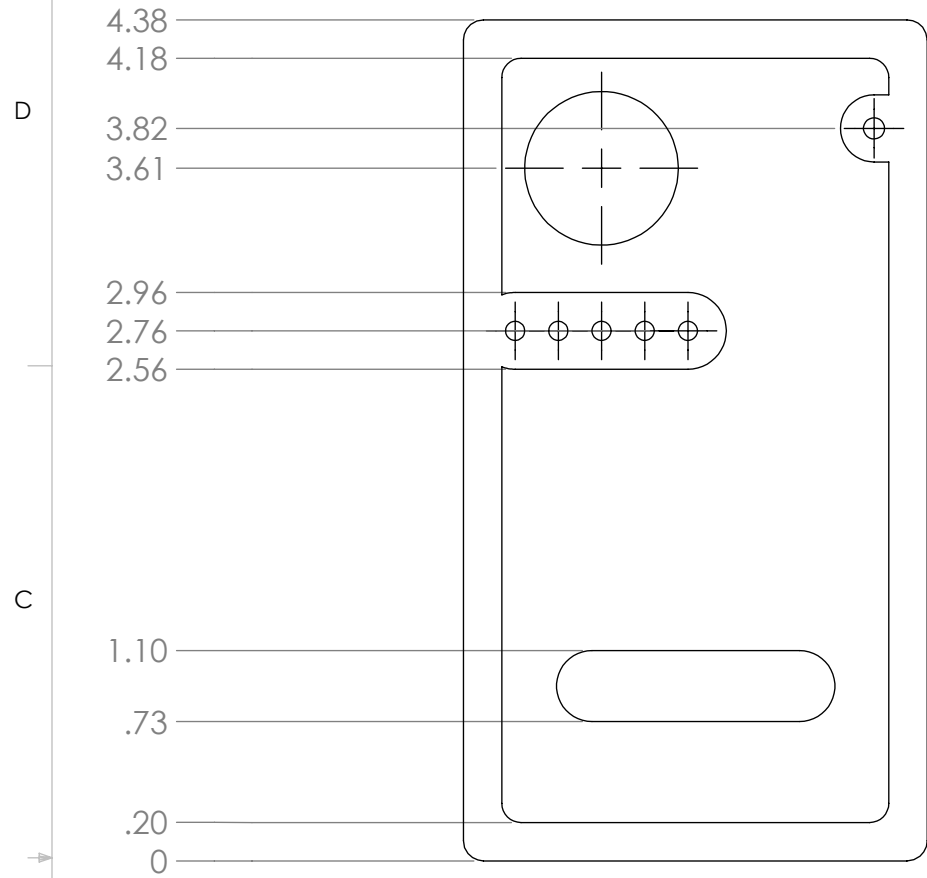

Type: Silicone rubber molded gasket with silicone / acrylic adhesive  
 Size: 111.2mm x 61.36mm x 6.86mm tall  
 Silicone: Molded black, Durometer 30 Shore A  
 Adhesive: .1mm thick DSMS differential adhesive. Silicone adhesive on one side,

UNLESS OTHERWISE SPECIFIED:  
 DIMENSIONS ARE IN: INCHES  
 TOLERANCES: .XX:  $\pm 0.03$   
 .XXX:  $\pm 0.005$   
 ANGULAR: .X\*: 1°  
 .XX\*: 0.5°  
 BREAK EDGES: .005 - .020  
 FILLETS: .005 - .020  
 SURFACE FINISH:  
 GEOMETRIC TOLERANCING  
 PER: ASME Y14.5 -2009  
 MATERIAL: BLACK 30D SHORE A SILICONE  
 FINISH: SEE DRAWING NOTES  
 DO NOT SCALE DRAWING

	NAME	DATE
DRAWN	TC	11/11/19
CHECKED	RB	11/11/19
COMMENTS:		

REF. NUMBER: SN0279	
 706 EXECUTIVE BLVD. SUITE B VALLEY COTTAGE, NY 10989	
TITLE: FULL CAP GASKET SEAL	
SIZE <b>B</b>	DWG. NO. SN0270-WT
SCALE: NA	WEIGHT:
REV <b>C</b>	SHEET 1 OF 1