

REVISIONS			
REV.	DESCRIPTION	DATE	ENG
A	INITIAL REV.	06/08/22	MOB

D
C
B
A

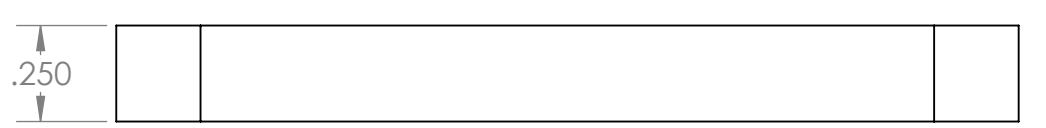
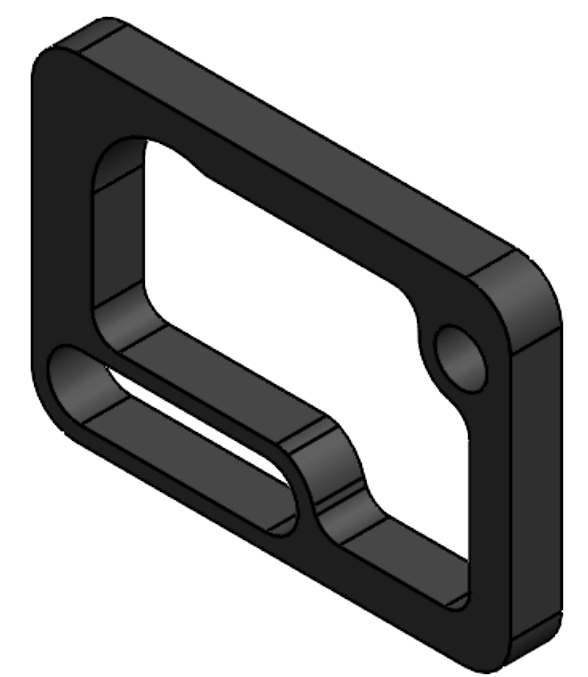
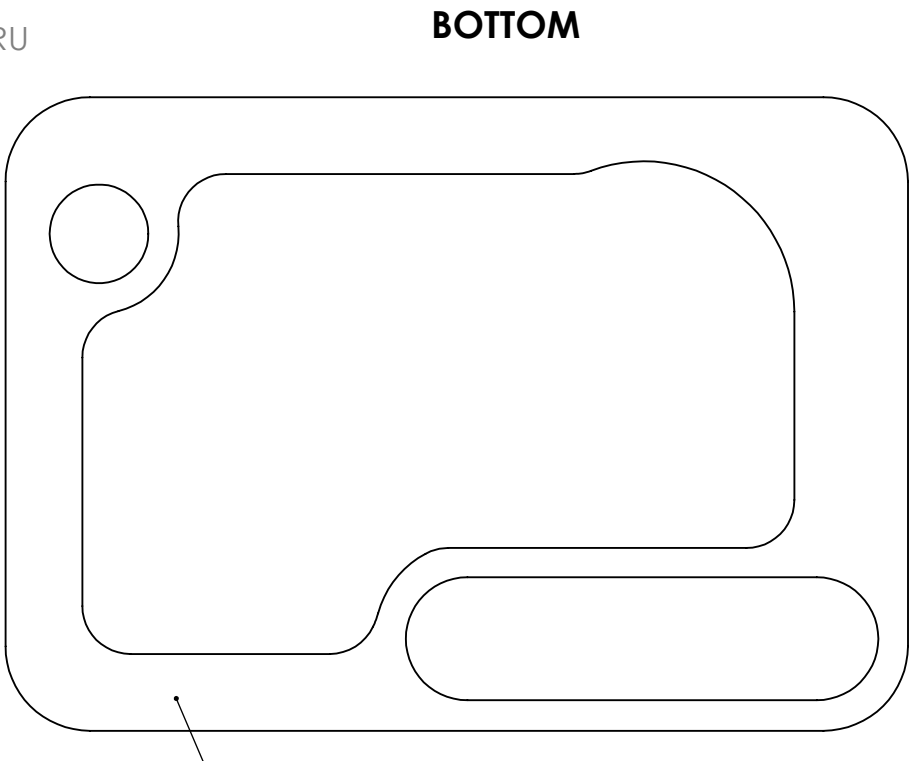
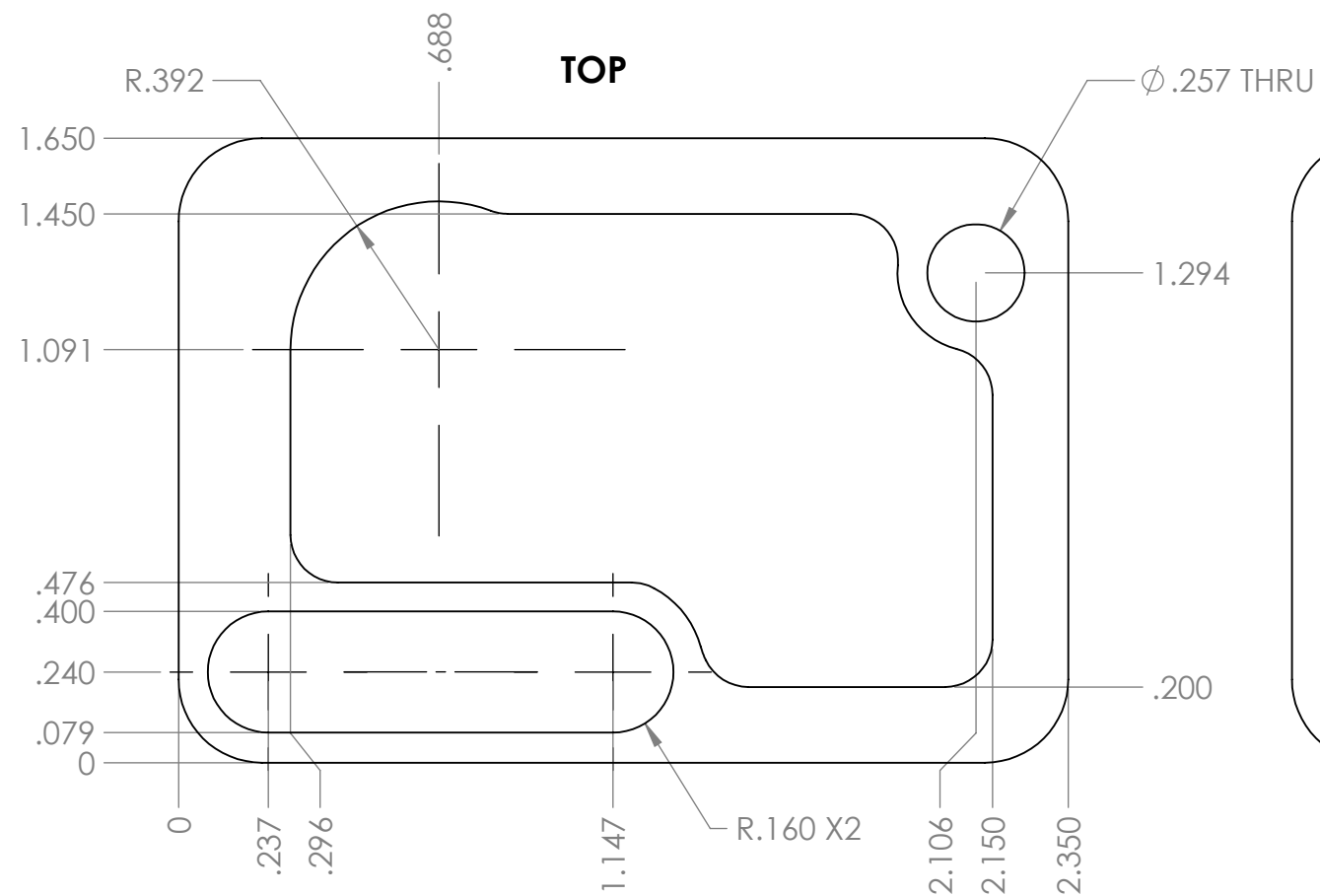

- NOTES:
1. MATERIAL: BISCO HT-800 MEDIUM SILICONE FOAM.
 2. COMPRESSION FORCE DEFLECTION: 9 PSI.
 3. ADHESIVE: 3M ADHESIVE 350, 9485PC
 4. COLOR: BLACK
 5. DIMENSIONS NOT SHOWN SHALL BE DERIVED FROM CAD MODEL GEOMETRY.

UNLESS OTHERWISE SPECIFIED:
 DIMENSIONS ARE IN: INCHES
 TOLERANCES: .XX: ± 0.03
 .XXX: ± 0.005
 ANGULAR: .X°: 1°
 .XX°: 0.5°
 BREAK EDGES: .005 - .020
 FILLETS: .005 - .020
 SURFACE FINISH:
 GEOMETRIC TOLERANCING
 PER: ASME Y14.5 -2009
 MATERIAL: SEE DRAWING NOTES
 FINISH: SEE DRAWING NOTES
 DO NOT SCALE DRAWING

	NAME	DATE
DRAWN	MOB	06/08/22
CHECKED	RB	06/08/22
COMMENTS:		
PROPRIETARY AND CONFIDENTIAL		
THE INFORMATION CONTAINED IN THIS DRAWING IS THE SOLE PROPERTY OF SUPPLYNET, INC. ANY REPRODUCTION IN PART OR AS A WHOLE WITHOUT THE WRITTEN PERMISSION OF SUPPLYNET INC. IS PROHIBITED.		
CAGE CODE: 1HJX9		

REF. NUMBER: SN0934		
SupplyNet		706 EXECUTIVE BLVD SUITE B VALLEY COTTAGE, NY 10989
TITLE: BATTERY FACE SEALING GASKET FOR CONN-BB2590SMBUS ASSEMBLY		
SIZE B	DWG. NO. SN0271-WT	REV A
SCALE: NA	WEIGHT:	SHEET 1 OF 1

8 7 6 5 4 3 2 1