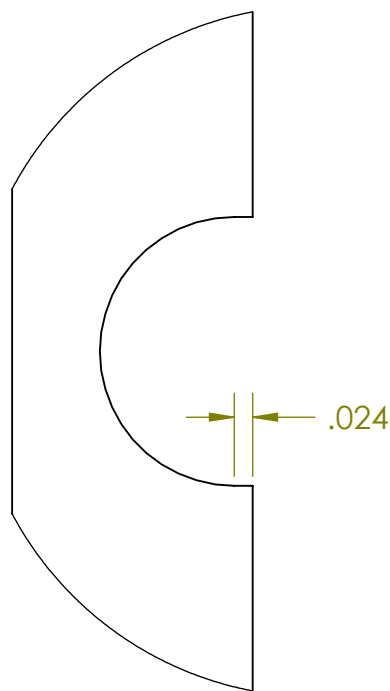

TABLE 1		
PART NUMBER	COMPRESSION FORCE DEFLECTION	MATERIAL
SN00278Z-1	9 (PSI)	HT 800
SN00278Z-2	16 (PSI)	HT 820
SN00278Z-3	22 (PSI)	HT 840

REV	DATE	DESCRIPTION OF CHANGE	ENG
B	11/28/2018	FILLET ADDED (ZONE C5), WALL THICKENED (ZONE C5)	LS

D
C
B
A



**DETAIL A
SCALE 4 : 1**

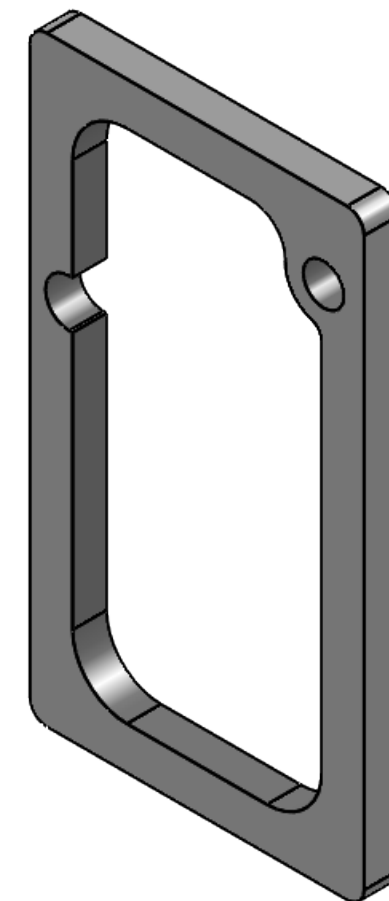
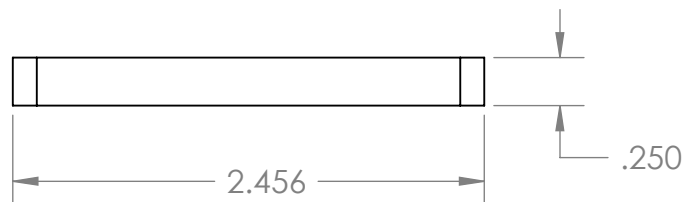
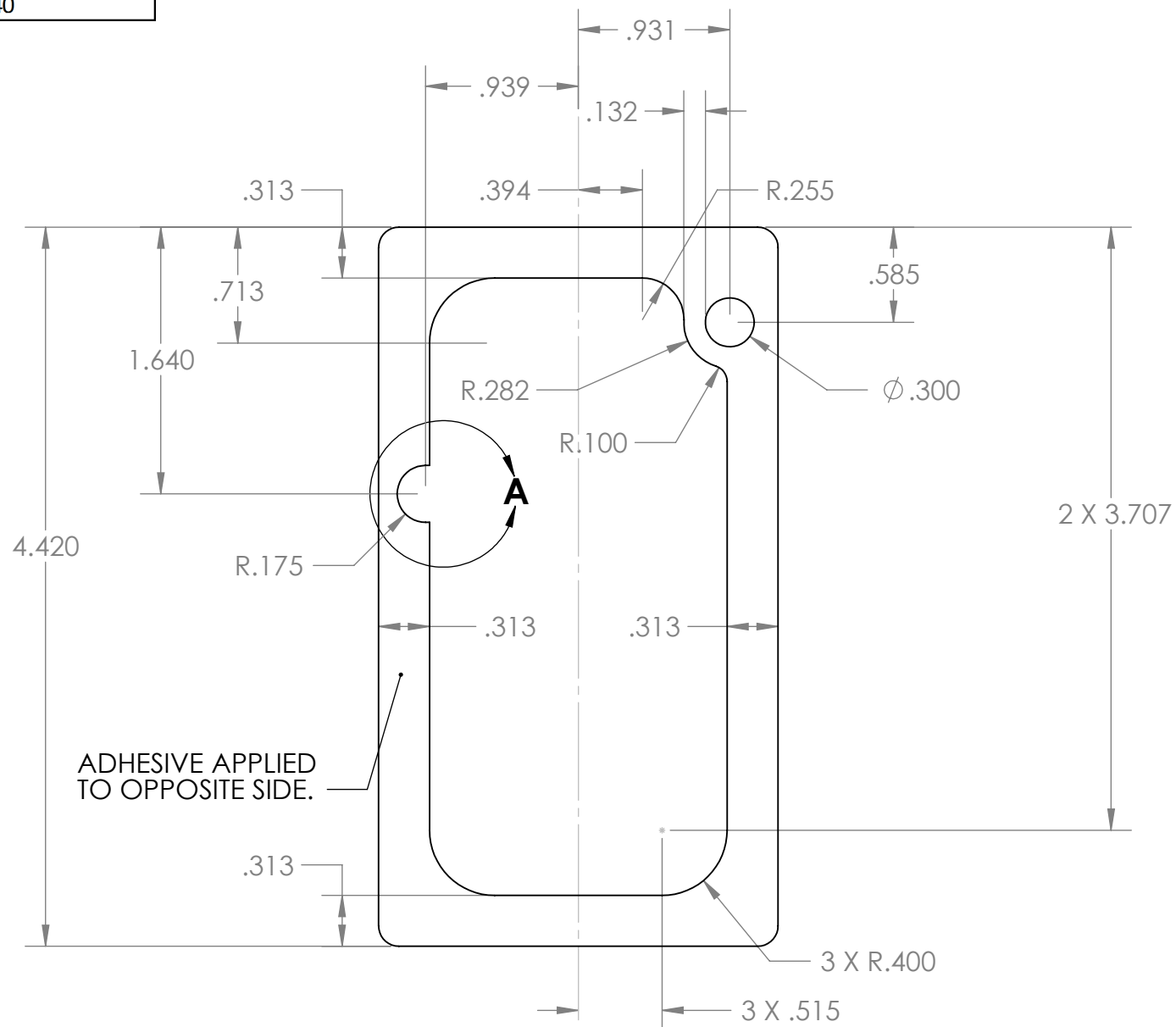

- NOTES:
 1) MATERIAL: BISCO SILICONE
 2) SPECIFICATION: TBD
 3) COLOR: GRAY.
 4) PART NUMBERING PER TABLE 1.
 5) ADHESIVE APPLIED ON ONE SIDE ONLY.

UNLESS OTHERWISE SPECIFIED:
 DIMENSIONS ARE IN: INCHES
 TOLERANCES: .XX: ± 0.03
 .XXX: ± 0.005
 ANGULAR: .X°: 1°
 .XX°: 0.5°
 BREAK EDGES: .005 - .020
 FILLETS: .005 - .020
 SURFACE FINISH:
 GEOMETRIC TOLERANCING
 PER: ASME Y14.5 -2009
 MATERIAL: SEE DRAWING NOTES
 FINISH: SEE DRAWING NOTES
 DO NOT SCALE DRAWING

	NAME	DATE
DRAWN	TC	05/08/13
CHECKED	RJB	05/08/13
COMMENTS:		
PROPRIETARY AND CONFIDENTIAL		
THE INFORMATION CONTAINED IN THIS DRAWING IS THE SOLE PROPERTY OF SUPPLYNET, INC. ANY REPRODUCTION IN PART OR AS A WHOLE WITHOUT THE WRITTEN PERMISSION OF SUPPLYNET INC. IS PROHIBITED.		
CAGE CODE: 1HJX9		

PART NUMBER: SN0278Z-X

SupplyNet 706 EXECUTIVE BLVD.
 SUITE B
 VALLEY COTTAGE, NY 10989

TITLE:

GASKET

SIZE	DWG. NO.	REV
B	SN0278Z-X	B

SCALE: NA WEIGHT: SHEET 1 OF 1

8 7 6 5 4 3 2 1