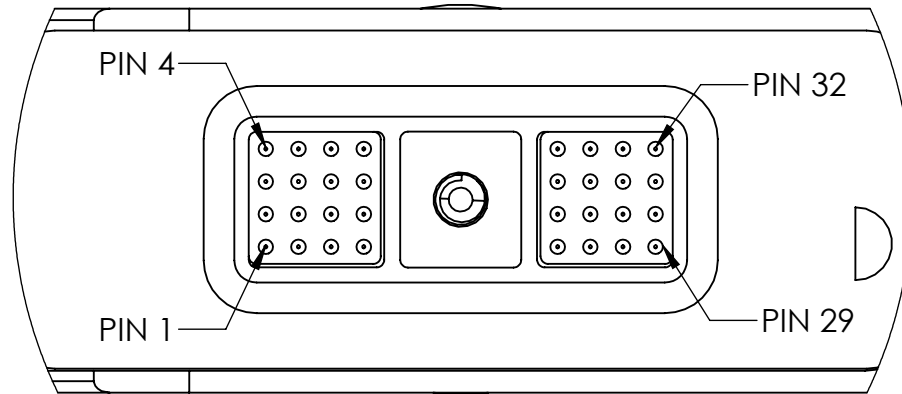

TABLE 1 WIRE RUN LIST	
PIN NUMBER	WIRE COLOR
13	RED/WHITE
15	RED
16	YELLOW
17	ORANGE/WHITE
18	BROWN/WHITE
19	GREEN/WHITE
20	BLACK/WHITE
21	BROWN
22	ORANGE
23	BLACK
24	YELLOW/WHITE
28	GREEN

TABLE 2 WIRE LENGTHS	
-XX	LENGTH IN FEET
03	3 FEET
06	6 FEET
10	10 FEET
12	12 FEET
14	14 FEET
16	16 FEET
24	24 FEET
25	25 FEET

**DETAIL A  
SCALE 2 : 1**



REV	DATE	DESCRIPTION OF CHANGE	ENG
B	11/17/20	ADDED PCB TO BOM	TC

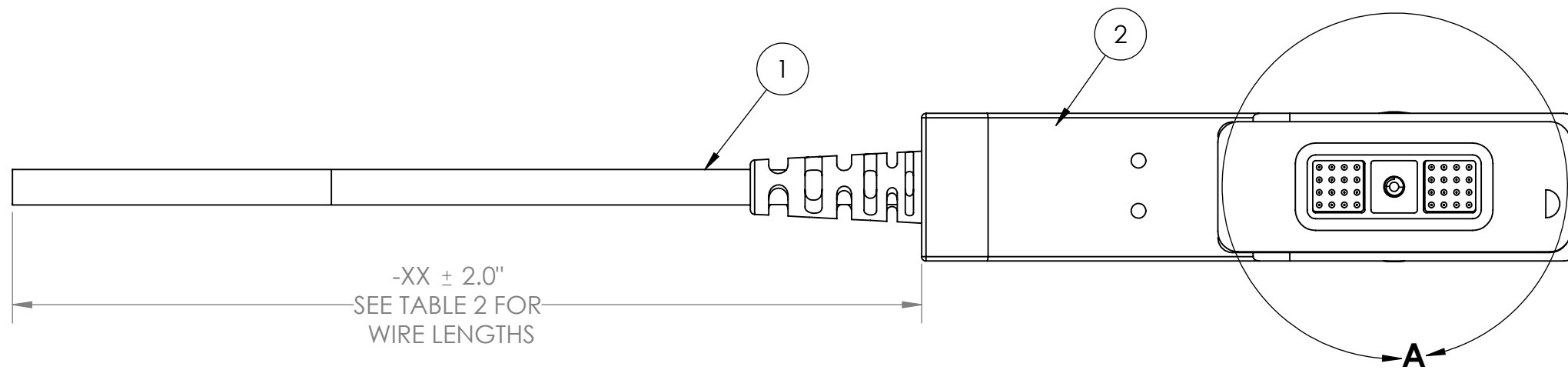
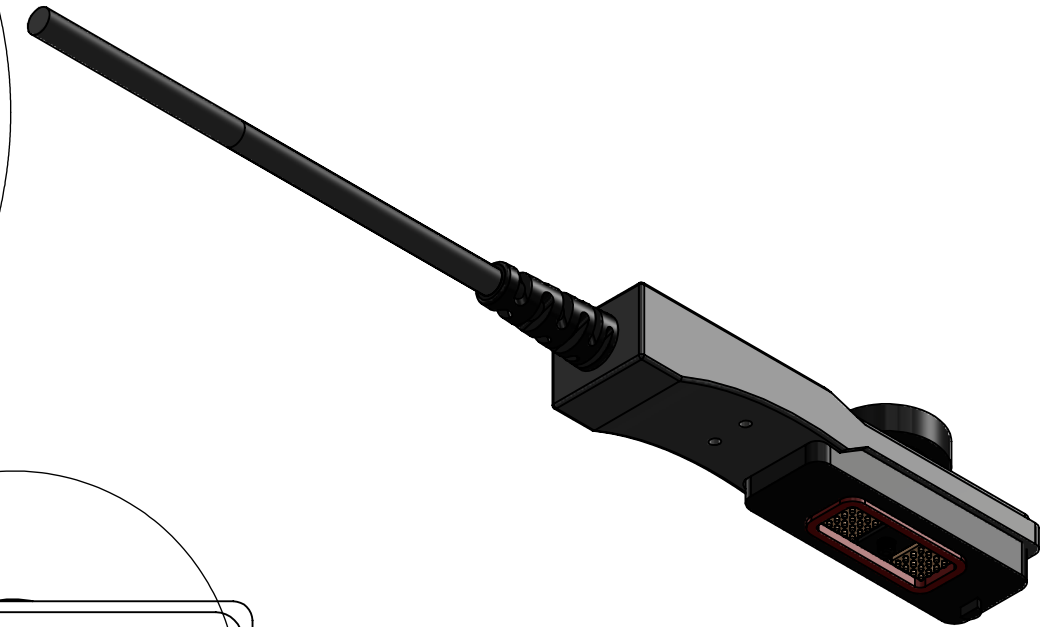

BILL OF MATERIALS				
ITEM NO.	PART NUMBER	QTY	NAME	COMMENTS
1	51245	AR	WIRE	
2	TE-32C-ASSY	1	CONNECTOR ASSEMBLY	INCLUDES HOUSING, FASTENERS, THUMBWHEEL. PROVIDED BY SUPPLYNET
3	SN0072	1	PCB	

**NOTES:**

- CABLE: 26 AWG, 12 CONDUCTOR, OD: 0.230 NOMINAL. POLYURETHANE INSULATION. OUTER SHIELD 38 AWG, TIN PLATED COPPER BRAID, 90% COVERAGE. C&M PN 51245.
- PRE-MOLD USING TOOLING PN 1071557
- OVERMOLD USING TOOLING PN 1071558
- OVERMOLD MATERIAL: 90A POLYETHER-TYPE THERMOPLASTIC POLYURETHANE (TPU).
- JACKET: BLACK MATTE FINISH.
- E33,E34 IS CHASSIS GROUND
- SOLDERING IAW IPC-J-STD-001 CLASS II AS APPLICABLE.
- CABLE ASSEMBLIES TO BE 100% TESTED FOR CONTINUITY, SHORTS AND INSULATION RESISTANCE (250V @100MOHM MINIMUM)
- IDENTIFICATION: BAG AND IDENTIFY ON PACKAGING THE FOLLOWING INFORMATION FOR EACH PART DELIVERED. UOS PART MARKING ON THE WIRE IS PROHIBITED:  
**PN: TE-32C-XX REV X (REV MARKING PER PO)**  
**CAGE CODE: 1HJX9**  
**DATE OF MFG: MM/YY**
- WIRING FUNCTION: TABLE 1 WIRE RUN LIST
- MANUFACTURE AND INSPECT IAW IPC/WHMA A-620 CLASS 2.

UNLESS OTHERWISE SPECIFIED:  
 DIMENSIONS ARE IN: INCHES  
 TOLERANCES: .XX: ± 0.03  
 .XXX: ± 0.005  
 ANGULAR: .X°: 1°  
 .XX°: 0.5°  
 BREAK EDGES: .005 - .020  
 FILLETS: .005 - .020  
 SURFACE FINISH:  
 GEOMETRIC TOLERANCING  
 PER: ASME Y14.5 -2009  
 MATERIAL: SEE DRAWING NOTES  
 FINISH: SEE DRAWING NOTES  
 DO NOT SCALE DRAWING

NAME	DATE
DRAWN: TC	10/09/15
CHECKED: RJB	10/09/15
COMMENTS:	
<b>PROPRIETARY AND CONFIDENTIAL</b> THE INFORMATION CONTAINED IN THIS DRAWING IS THE SOLE PROPERTY OF SUPPLYNET, INC. ANY REPRODUCTION IN PART OR AS A WHOLE WITHOUT THE WRITTEN PERMISSION OF SUPPLYNET INC. IS PROHIBITED.	
<b>CAGE CODE: 1HJX9</b>	

REF. NUMBER: SN0277	
<b>SupplyNet</b> 706 EXECUTIVE BLVD. SUITE B VALLEY COTTAGE, NY 10989	
TITLE: SIDE EXIT PRC-152 32 PIN DATA CABLE, J3 PORT	
SIZE: <b>B</b>	DWG. NO.: <b>TE-32C-XX</b>
REV: <b>B</b>	
SCALE: NA	WEIGHT:
SHEET 1 OF 1	