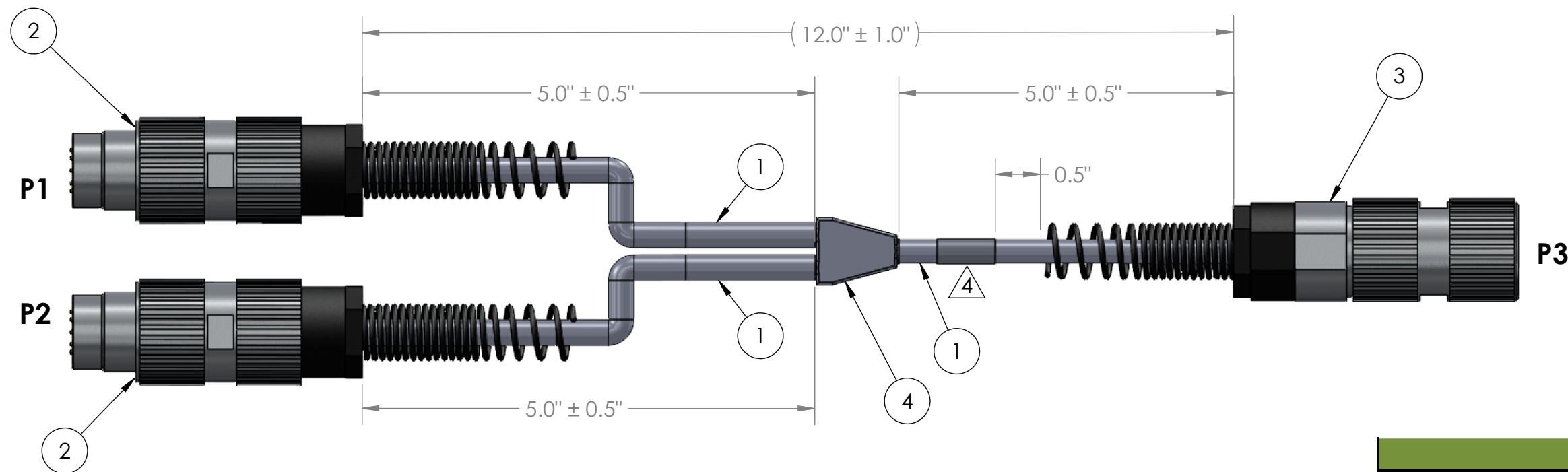
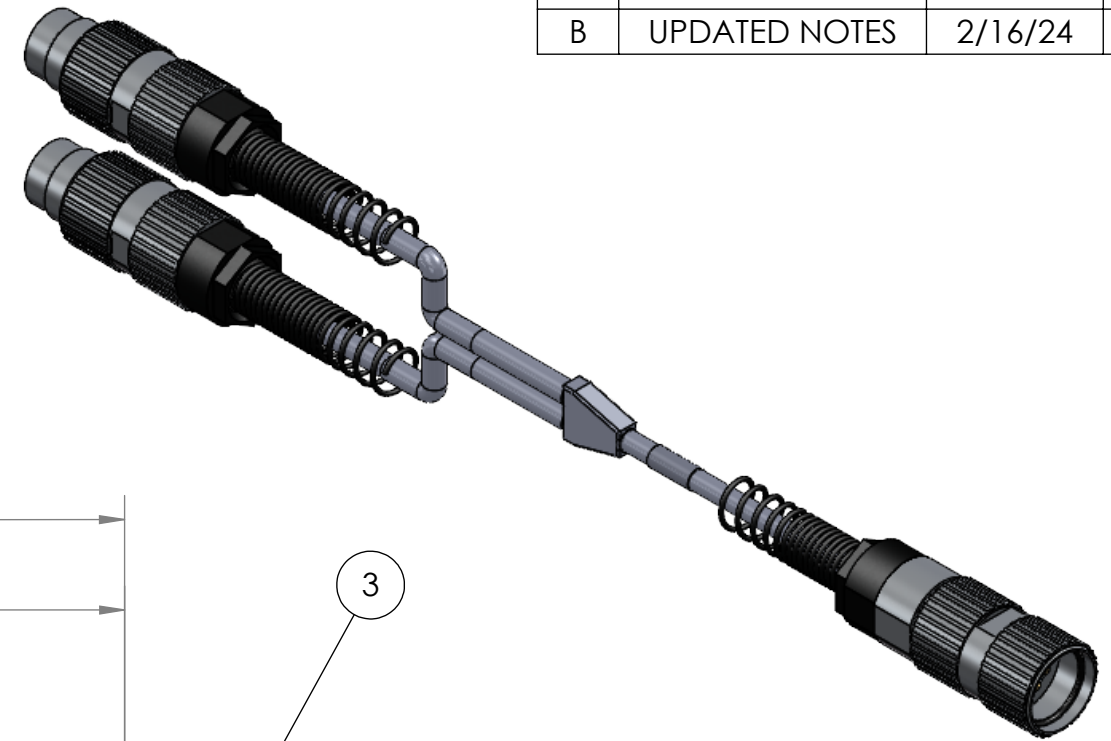

TABLE 1: WIRE RUN LIST				
U-328/U P1	WIRE COLOR	U-328/U P2	WIRE COLOR	U-329/U P3
A	BLACK	A	BLACK	A
B	RED	B	RED	B
C	BROWN	C	BROWN	C
D	WHITE	D	WHITE	D
E	GREEN	E	GREEN	E
F	BLUE	F	BLUE	F
SHELL	SHIELD	SHELL	SHIELD	SHELL

REVISIONS			
REV	DESCRIPTION	DATE	ENG
A	INITIAL RELEASE	8/22/15	LS
B	UPDATED NOTES	2/16/24	CWA



NOTES:

- WIRING SHALL BE DONE IN ACCORDANCE WITH TABLE 1 WIRE RUN LIST.
- COVER SOLDERED CONNECTIONS WITH SHRINK BOOT.
- LOCTITE 242 OR EQUIVALENT SHALL BE APPLIED TO ALL THREADED METAL CONNECTIONS.
- MARKING REQUIREMENTS:
 - LABEL(S) SHALL BE MARKED IN ACCORDANCE WITH MIL-STD-130 AS APPLICABLE.
 - LABEL(S) SHALL BE WHITE WITH BLACK TEXT.
 - LABEL(S) SHALL BE PLACED WHERE SHOWN IN DRAWING.
 - ADHESIVE WRAP AROUND LABEL(S) MAY BE USED.
 - LABEL SHALL BE MARKED WITH THE BELOW INFORMATION ONLY. REV MARKING PER PO.
(YYYY=YEAR OF MFG, MM=MONTH OF MFG, DD=DAY OF MFG, XXXX=PO NUMBER)
PN: U-329/Y REV.X
CAGE: 1HJX9
LOT: TYYYYMMDDPXXXX
- PACKAGING REQUIREMENTS:
 - EACH COMPLETED ASSEMBLY SHALL BE PACKAGED IN A 8.0"x10.0" 4MIL MIN. THICK ZIP POLYBAG.
 - CONNECTOR(S) SHALL BE PACKAGED TO PREVENT DAMAGE DURING SHIPPING. BUBBLE WRAP OR PROTECTIVE COVER MUST BE USED.
 - POLYBAG SHALL BE MARKED WITH SUPPLYNET LOGO, PRODUCT QR CODE, PART NUMBER, CAGE CODE, AND LOT NO, PER SN-STD-LBL REQUIREMENTS.
- WORKMANSHIP REQUIREMENTS:
 - MANUFACTURE TO IAW/WHMA A-620 CLASS 2 REQUIREMENTS.
 - SOLDERING SHALL BE COMPLIANT WITH IAW J-STD-001 AS APPLICABLE.
 - CONNECTOR(S) AND WIRE SHALL BE FREE FROM ANY SCRATCHES, CHIPS, AND DEFECTS.
- INSPECTION REQUIREMENTS:
 - EACH COMPLETED ASSEMBLY TO BE 100% TESTED FOR SHORTS, CONTINUITY, AND JACKET RESISTANCE (250V @100MOHM MIN.)
 - INSPECT TO IPC/WHMA A-620 CLASS 2 REQUIREMENTS.

BILL OF MATERIALS			
ITEM NO.	PART NUMBER	QTY	NAME
1	51395	23"	6 C, AWG 22, .226 DIA.
2	U-328/U	2	U-328/U Audio Conn
3	U-329/U	1	U-329/U FEMALE
4	11090724	1	Y-TYPE STRAIN RELIEF

UNLESS OTHERWISE SPECIFIED:
 DIMENSIONS ARE IN: INCHES
 TOLERANCES: .XX: ± 0.03
 .XXX: ± 0.005
 ANGULAR: .X°: 1°
 .XX': 0.5°
 BREAK EDGES: .005 - .020
 FILLETS: .005 - .020
 SURFACE FINISH:
 GEOMETRIC TOLERANCING
 PER: ASME Y14.5 -2009
 MATERIAL: SEE DRAWING NOTES
 FINISH: SEE DRAWING NOTES
 DO NOT SCALE DRAWING

NAME	DATE
DRAWN: LS	8/22/15
CHECKED: RJB	8/24/15
COMMENTS:	
PROPRIETARY AND CONFIDENTIAL THE INFORMATION CONTAINED IN THIS DRAWING IS THE SOLE PROPERTY OF SUPPLYNET, INC. ANY REPRODUCTION IN PART OR AS A WHOLE WITHOUT THE WRITTEN PERMISSION OF SUPPLYNET INC. IS PROHIBITED.	
CAGE CODE: 1HJX9	

REF. NUMBER: SNO403

SupplyNet DESIGN ENGINEERING MANUFACTURING

TITLE: **U-329 SPLITTER CABLE 12 INCH**

SIZE B	DWG. NO. U-329/Y	REV B
SCALE: NA	WEIGHT:	SHEET 1 OF 1