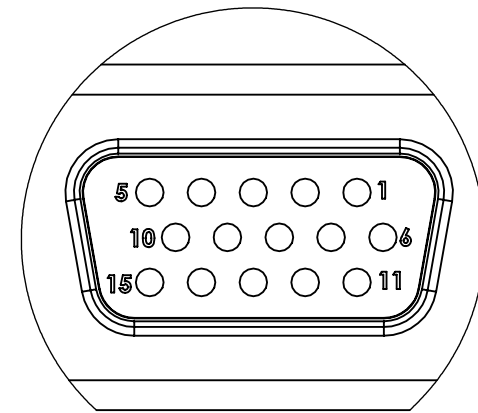
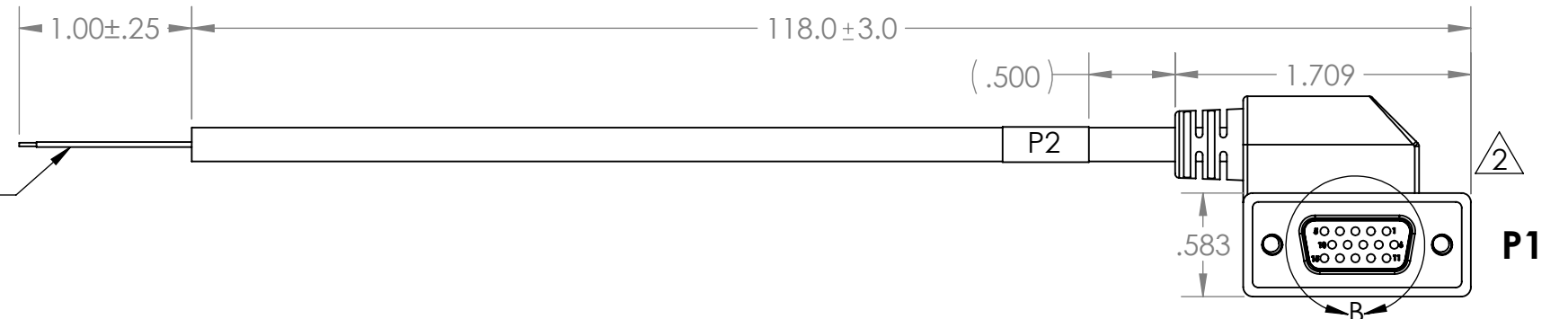
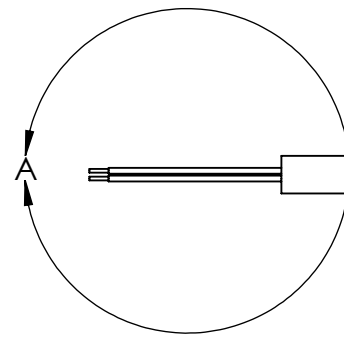
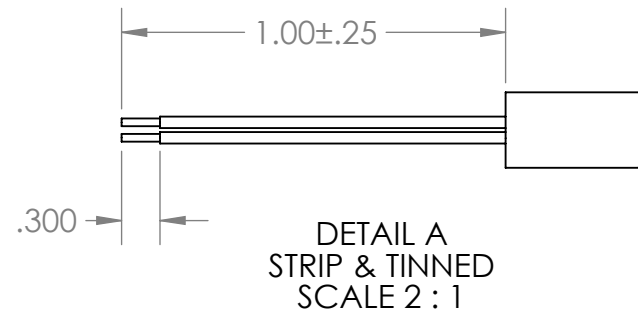

TABLE 1: WIRE RUN LIST		
P1	WIRE COLOR	SIGNAL
3	BLACK	GND
7	WHITE	GPS HAVE QUICK

REVISIONS			
REV.	DESCRIPTION	DATE	ENG
A	INITIAL RELEASE	02/26/2024	MOB
B	UPDATED WIRE LENGTH, ADDED STRIP & TIN	11/11/2024	CWA



DETAIL B
P1 PINOUT
(MATING FACE VIEW)
SCALE 3 : 1

NOTES:

1. WIRING SHALL BE DONE IN ACCORDANCE WITH TABLE 1 WIRE RUN LIST
2. DAGR PLUG OVER-MOLD SHALL HAVE 2 RAISED DOTS. INDICATING J2 CONNECTOR.
3. MARKING REQUIREMENTS:
 1. LABEL SHALL BE MARKED IN ACCORDANCE WITH MIL-STD-130.
 2. LABEL TO BE BLACK POLYOLEFIN HEAT SHRINK WITH WHITE LETTERING.
 3. LABELS SHALL BE LOCATED WHERE SHOWN.
 4. LABEL MUST BE MARKED WITH "P2"
4. PACKAGING REQUIREMENTS:
 - A. EACH COMPLETED ASSEMBLY SHALL BE PACKAGED IN A ZIP POLYBAG.
 - B. CONNECTOR SHALL BE PACKAGED TO PREVENT DAMAGE DURING SHIPPING, BUBBLE WRAP OR PROTECTIVE COVER MUST BE USED.
 - C. POLYBAG SHALL BE MARKED WITH SUPPLYNET LOGO, PRODUCT QR CODE, PART NUMBER, CAGE CODE, AND LOT NO. PER SN=STD-LBL REQUIREMENTS.
5. WORKMANSHIP REQUIREMENTS:
 - A. MANUFACTURE TO IAW/WHMA A-620 CLASS 2 REQUIREMENTS.
 - B. SOLDERING SHALL BE COMPLIANT WITH IAW J-STD-001 AS APPLICABLE.
 - C. CONNECTOR AND WIRE SHALL BE FREE FROM ANY SCRATCHES, CHIPS, AND DEFECTS.
6. INSPECTION REQUIREMENTS:
 - A. EACH COMPLETED ASSEMBLY TO BE 100% TESTED FOR SHORTS, CONTINUITY, AND JACKET RESISTANCE (250V @ 100MOHM MIN.)
 - B. INSPECT TO IPC/WHMA A-620 CLASS 2 REQUIREMENTS.

BILL OF MATERIALS			
ITEM NO.	PART NO.	QTY	NAME/DESCRIPTION
1	609-4045-ND	1	CONNECTOR, HD15 FEMALE, SOCKETS
2	M3432-02LHE(2/20)SJO250	121"	CABLE, 2C, AWG 20, SHIELDED, .250 IN. DIA.

UNLESS OTHERWISE SPECIFIED:
 DIMENSIONS ARE IN: INCHES
 TOLERANCES: .XX: ± 0.03
 .XXX: ± 0.005
 ANGULAR: .X°: 1°
 .XX*: 0.5°
 BREAK EDGES: .005 - .020
 FILLETS: .005 - .020
 SURFACE FINISH:
 GEOMETRIC TOLERANCING
 PER: ASME Y14.5 -2009
 MATERIAL: SEE DRAWING NOTES
 FINISH: SEE DRAWING NOTES
 DO NOT SCALE DRAWING

NAME	DATE
DRAWN MOB	2/26/2024
CHECKED MOB	2/26/2024
COMMENTS:	

PROPRIETARY AND CONFIDENTIAL
 THE INFORMATION CONTAINED IN THIS DRAWING IS THE SOLE PROPERTY OF SUPPLYNET, INC. ANY REPRODUCTION IN PART OR AS A WHOLE WITHOUT THE WRITTEN PERMISSION OF SUPPLYNET INC. IS PROHIBITED.

REF. NUMBER: SN1137

SupplyNet DESIGN ENGINEERING MANUFACTURING

TITLE:
DAGR J2 HAVE QUICK CABLE

SIZE	DWG. NO.	REV
B	SN-987-5002-001	B

CAGE CODE: 1HJX9

SCALE: NA WEIGHT: SHEET 1 OF 1