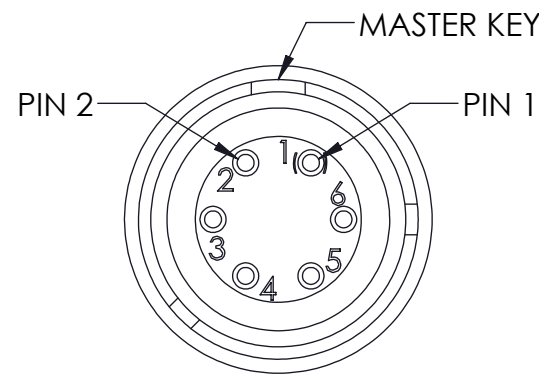
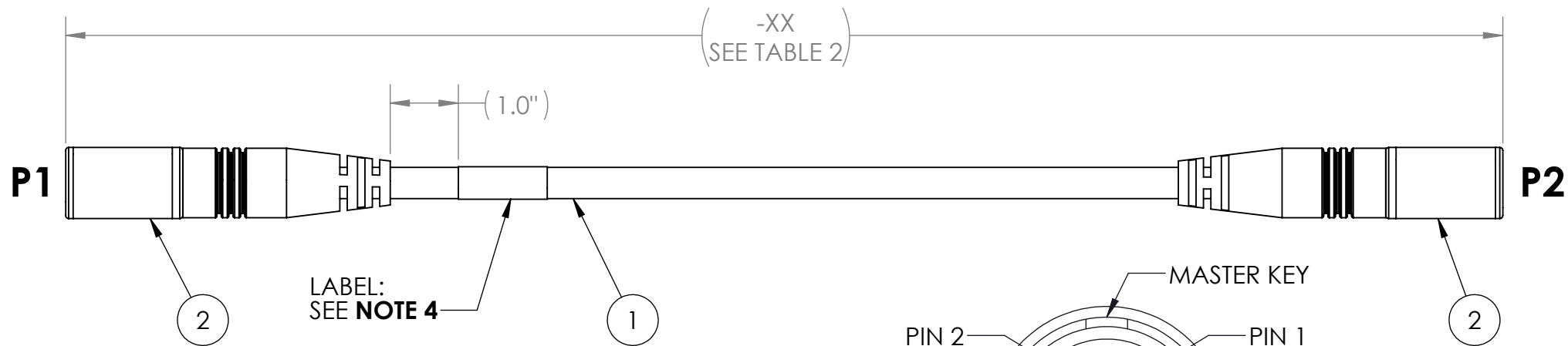
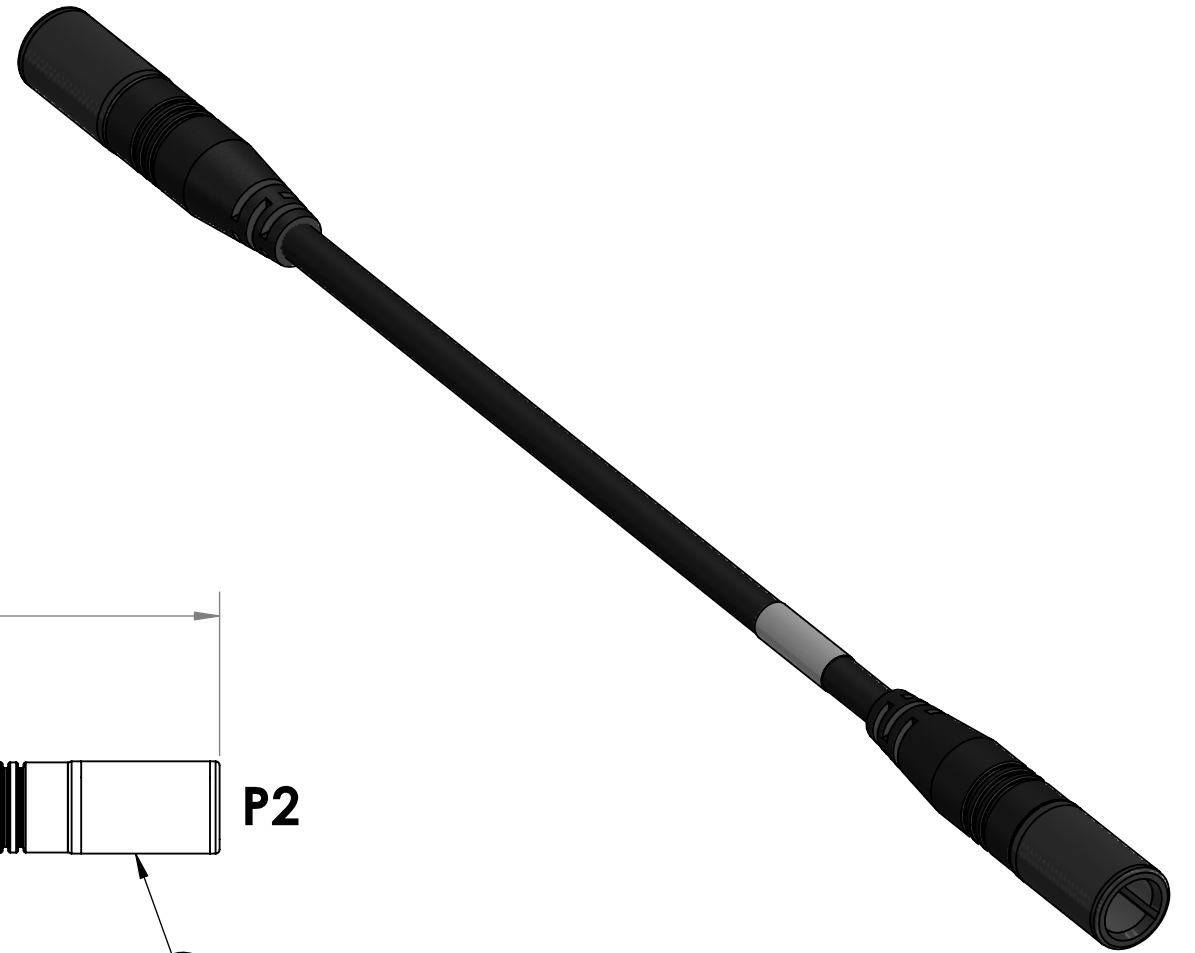

TABLE 1: WIRE RUN LIST		
P1 (ITEM 1)	COLOR	P2 (ITEM 2)
1	RED	1
2	BLACK	2
3	BROWN	3
4	GREEN	4
5	WHITE	5
6	ORANGE	6
SHELL	SHIELD	SHELL

TWISTED PAIR  
SEE NOTE #6

TABLE 2: WIRE LENGTH		
PART NUMBER & PART MARKING	"L" DIMENSION (INCHES)	TOLERANCE (INCHES)
SN-1088-.5	6	+1.0", -0.0"
SN-1088-01	12	+1.0", -0.0"
SN-1088-02	24	+2.0", -0.0"
SN-1088-03	36	+2.0", -0.0"
SN-1088-04	48	+2.0", -0.0"
SN-1088-06	72	+4.0", -0.0"
SN-1088-08	96	+4.0", -0.0"
SN-1088-10	120	+6.0", -0.0"
SN-1088-12	144	+6.0", -0.0"
SN-1088-18	216	+6.0", -0.0"
SN-1088-20	240	+6.0", -0.0"
SN-1088-25	300	+6.0", -0.0"
SN-1088-30	360	+18.0", -0.0"

REV	DATE	DESCRIPTION OF CHANGE	ENG
C	5/7/2019	ADDED NOTE #6, REMOVED HI-POT TEST	LS



PIN LAYOUT OF P1 AND P2 (FRONT FACE)

**NOTES:**

- JACKET: BLACK MATTE FINISH.
- SOLDERING IAW IPC-J-STD-001 CLASS II AS APPLICABLE.
- CABLE ASSEMBLIES TO BE 100% TESTED FOR CONTINUITY AND SHORTS.
- IDENTIFICATION: COMPLETED ASSEMBLIES ARE TO BE PLACED IN A ZIP POLY-BAG. PLACE A LABEL ON THE BAG WITH THE FOLLOWING INFORMATION. PLACE A WRAP-AROUND LABEL WHERE INDICATED ON DRAWING WITH THE FOLLOWING INFORMATION. UOS PART MARKING ON THE WIRE IS PROHIBITED:  
**PN: SN-1088 REV X (REV MARKING PER PO)**  
**CAGE CODE: 1HJX9**  
**DATE OF MFGR: MM/YY**
- WIRING FUNCTION: SEE TABLE 1
- CONNECT TWISTED PAIR SHIELD/DRAIN WIRE TO OVERALL SHIELD AT BOTH ENDS OF CABLE.
- MANUFACTURE AND INSPECT IAW IPC/WHMA A- 620 CLASS 2.

BILL OF MATERIALS				
ITEM NO.	PART NUMBER	QTY	NAME	COMMENTS
1	880007S7	36"	7C COMPOSITE WIRE	
2	807-348-01ZNU6-6SY	2	CONNECTOR, FEMALE	GLENAIR PN

UNLESS OTHERWISE SPECIFIED:  
 DIMENSIONS ARE IN: INCHES  
 TOLERANCES: .XX: ± 0.03  
 .XXX: ± 0.005  
 ANGULAR: .X°: 1°  
 .XX': 0.5°  
 BREAK EDGES: .005 - .020  
 FILLETS: .005 - .020  
 SURFACE FINISH:  
 GEOMETRIC TOLERANCING PER: ASME Y14.5 -2009  
 MATERIAL: SEE DRAWING NOTES  
 FINISH: SEE DRAWING NOTES  
 DO NOT SCALE DRAWING

NAME	DATE
DRAWN: TC	08/08/16
CHECKED: RJB	08/08/16
COMMENTS:	
<b>PROPRIETARY AND CONFIDENTIAL</b> THE INFORMATION CONTAINED IN THIS DRAWING IS THE SOLE PROPERTY OF SUPPLYNET, INC. ANY REPRODUCTION IN PART OR AS A WHOLE WITHOUT THE WRITTEN PERMISSION OF SUPPLYNET INC. IS PROHIBITED.	
<b>CAGE CODE: 1HJX9</b>	

REF. NUMBER: SNO421

**SupplyNet** 706 EXECUTIVE BLVD. SUITE B VALLEY COTTAGE, NY 10989

TITLE: **NETT WARRIOR CABLE FEMALE TO FEMALE**

SIZE <b>B</b>	DWG. NO. <b>SN-1088-XX</b>	REV <b>C</b>
SCALE: NA	WEIGHT:	SHEET 1 OF 1